

## OPAx354-Q1 250MHz、轨至轨 I/O CMOS 运算放大器

### 1 特性

- 符合汽车类应用的要求
- 具有符合 AEC Q100 标准的下列结果：
  - 器件温度等级：环境运行温度范围为  $-40^{\circ}\text{C}$  至  $+125^{\circ}\text{C}$
  - 器件 HBM ESD 分类等级 2
  - 器件 CDM ESD 分类等级：
    - OPA354A-Q1 和 OPA2354A-Q1 为 C6
    - OPA4354-Q1 为 C3
- 单位增益带宽：250MHz
- 高带宽：100MHz GBW 产品
- 高压摆率：150V/ $\mu\text{s}$
- 低噪声：6.5nV/ $\sqrt{\text{Hz}}$
- 轨至轨 I/O
- 高输出电流：> 100mA
- 出色的视频性能
  - 差动增益误差：0.02%
  - 差动相位误差：0.09°
  - 0.1dB 增益平坦度：40MHz
- 低输入偏置电流：3pA
- 静态电流：4.9mA
- 热关断
- 电源范围：2.5V 至 5.5V

### 2 应用

- 导航和雷达系统
- 盲点监测系统
- 短程到中程雷达添加了项目符号
- 视频处理
- 超声波
- 光网络、可调激光器
- 光电二极管互阻放大器
- 有源滤波器
- 高速积分器
- 模数转换器 (ADC) 输入缓冲器
- 数模转换器 (DAC) 输出放大器
- 条形码扫描器
- 通信

### 3 说明

OPAx354-Q1 系列高速电压反馈 CMOS 运算放大器专为视频应用和其他需要宽带宽的应用而设计。这些器件具有单位增益稳定性，可以驱动大型输出电流。差分增益为 0.02%，而差分相位为 0.09°。静态电流仅为每通道 4.9mA。

OPAx354-Q1 系列运算放大器针对低至 2.5V ( $\pm 1.25\text{V}$ ) 和高达 5.5V ( $\pm 2.75\text{V}$ ) 的单电源或双电源供电运行进行了优化。共模输入范围超出电源供电范围。电源轨的输出摆幅在 100mV 以内，从而支持宽动态范围。

单电源版本 (OPA354A-Q1) 可提供微型 SOT-23-5 (DBV) 封装。双电源版本 (OPA2354A-Q1) 可提供微型 VSSOP-8 (DGK) 封装并采用完全独立的电路，可将串扰降到最低并彻底消除相互干扰。双电源版本 (OPA4354-Q1) 可提供 TSSOP-14 (PW) 封装。该器件的规格支持在  $-40^{\circ}\text{C}$  至  $+125^{\circ}\text{C}$  的汽车温度范围内运行。

器件信息<sup>(1)</sup>

器件型号	封装 (引脚)	封装尺寸 (标称值)
OPA354A-Q1	SOT-23 (5)	2.90mm × 1.60mm
OPA2354A-Q1	VSSOP (8)	3.00mm × 3.00mm
OPA4354-Q1	TSSOP (14)	5.00mm × 4.40mm

(1) 如需了解所有可用封装，请参阅产品说明书末尾的可订购产品附录。

简化原理图

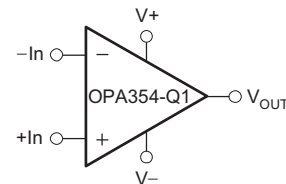

## 目录

<b>1</b>	特性 .....	<b>1</b>	7.4	Device Functional Modes .....	<b>20</b>
<b>2</b>	应用 .....	<b>1</b>	<b>8</b>	<b>Application and Implementation</b> .....	<b>21</b>
<b>3</b>	说明 .....	<b>1</b>	8.1	Application Information .....	<b>21</b>
<b>4</b>	修订历史记录 .....	<b>2</b>	8.2	Typical Applications .....	<b>21</b>
<b>5</b>	<b>Pin Configuration and Functions</b> .....	<b>3</b>	<b>9</b>	<b>Power Supply Recommendations</b> .....	<b>25</b>
<b>6</b>	<b>Specifications</b> .....	<b>6</b>	9.1	Power Dissipation .....	<b>26</b>
6.1	Absolute Maximum Ratings .....	<b>6</b>	<b>10</b>	<b>Layout</b> .....	<b>26</b>
6.2	ESD Ratings .....	<b>6</b>	10.1	Layout Guidelines .....	<b>26</b>
6.3	Recommended Operating Conditions .....	<b>6</b>	10.2	Layout Example .....	<b>27</b>
6.4	Thermal Information: OPA354A-Q1 .....	<b>6</b>	<b>11</b>	<b>器件和文档支持</b> .....	<b>28</b>
6.5	Thermal Information: OPA2354A-Q1 .....	<b>7</b>	11.1	文档支持 .....	<b>28</b>
6.6	Thermal Information: OPA4354A-Q1 .....	<b>7</b>	11.2	相关链接 .....	<b>28</b>
6.7	Electrical Characteristics .....	<b>8</b>	11.3	接收文档更新通知 .....	<b>28</b>
6.8	Typical Characteristics .....	<b>10</b>	11.4	社区资源 .....	<b>28</b>
<b>7</b>	<b>Detailed Description</b> .....	<b>15</b>	11.5	商标 .....	<b>28</b>
7.1	Overview .....	<b>15</b>	11.6	静电放电警告 .....	<b>28</b>
7.2	Functional Block Diagram .....	<b>15</b>	11.7	术语表 .....	<b>29</b>
7.3	Feature Description .....	<b>15</b>	<b>12</b>	<b>机械、封装和可订购信息</b> .....	<b>29</b>

## 4 修订历史记录

注：之前版本的页码可能与当前版本有所不同。

<b>Changes from Revision E (August 2016) to Revision F</b>	<b>Page</b>
• Deleted table note about input terminals and input signals from <i>Absolute Maximum Ratings</i> table .....	<b>6</b>

<b>Changes from Revision D (July 2016) to Revision E</b>	<b>Page</b>
• Changed the gain-bandwidth product typical value from 10 MHz back to 100 MHz in the <i>Electrical Characteristics</i> table ..	<b>8</b>

<b>Changes from Revision C (June 2016) to Revision D</b>	<b>Page</b>
• Changed the gain-bandwidth product typical value from 100 MHz to 10 MHz in the <i>Electrical Characteristics</i> table .....	<b>8</b>
• 已添加 添加了接收文档更新通知 和社区资源 部分 .....	<b>28</b>

<b>Changes from Revision B (December 2014) to Revision C</b>	<b>Page</b>
• 已添加 将 3 个额外的 应用 添加至应用 部分 .....	<b>1</b>
• Updated <i>ESD Ratings</i> table to show CDM value for OPA354A-Q1 and OPA2354A-Q1 .....	<b>6</b>

<b>Changes from Revision A (August 2009) to Revision B</b>	<b>Page</b>
• 已添加 处理额定值表, 特性 说明 部分、器件功能模式、应用和实施 部分、电源建议 部分、布局 部分、器件和文档支持 部分以及机械、封装和可订购信息 部分 .....	<b>1</b>
• 已添加 在产品说明书中添加了 OPA4354-Q1 器件 .....	<b>1</b>

## 5 Pin Configuration and Functions

**OPA354A-Q1 DBV Package  
5-Pin SOT-23  
Top View**

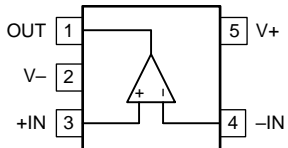

**Pin Functions: OPA354A-Q1**

PIN		I/O	DESCRIPTION
NAME	NO.		
+IN	3	I	Noninverting input
-IN	4	I	Inverting input
OUT	1	O	Output
V+	5	—	Positive (highest) supply
V-	2	—	Negative (lowest) supply

**OPA2354A-Q1 DGK Package  
8-Pin VSSOP  
Top View**

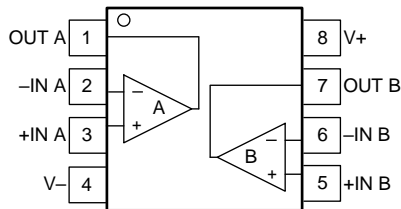

**Pin Functions: OPA2354A-Q1**

PIN		I/O	DESCRIPTION
NAME	NO.		
+IN A	3	I	Noninverting input, channel A
+IN B	5	I	Noninverting input, channel B
-IN A	2	I	Inverting input, channel A
-IN B	6	I	Inverting input, channel B
OUT A	1	O	Output, channel A
OUT B	7	O	Output, channel B
V+	8	—	Positive (highest) supply
V-	4	—	Negative (lowest) supply

**OPA4354-Q1 PW Package  
14-Pin TSSOP  
Top View**

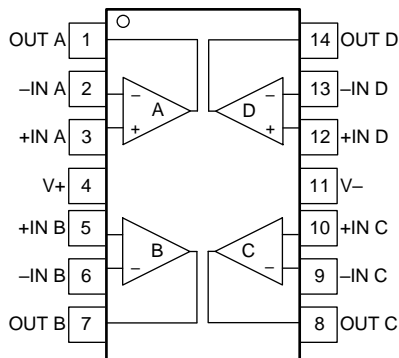

**Pin Functions: OPA4354-Q1**

PIN		I/O	DESCRIPTION
NAME	NO.		
+IN A	3	I	Noninverting input, channel A
+IN B	5	I	Noninverting input, channel B
+IN C	10	I	Noninverting input, channel C
+IN D	12	I	Noninverting input, channel D
-IN A	2	I	Inverting input, channel A
-IN B	6	I	Inverting input, channel B
-IN C	9	I	Inverting input, channel C
-IN D	13	I	Inverting input, channel D
OUT A	1	O	Output, channel A
OUT B	7	O	Output, channel B
OUT C	8	O	Output, channel C
OUT D	14	O	Output, channel D
V+	4	—	Positive (highest) supply
V-	11	—	Negative (lowest) supply

## 6 Specifications

### 6.1 Absolute Maximum Ratings

over operating free-air temperature range (unless otherwise noted) <sup>(1)</sup>

	MIN	MAX	UNIT
Supply voltage, V+ to V–, V <sub>S</sub>		7.5	V
Signal input terminals voltage, V <sub>IN</sub>	(V–) – 0.5	(V+) + 0.5	V
Output short-circuit duration <sup>(2)</sup>	Continuous		
Operating temperature, T <sub>A</sub>	–55	150	°C
Junction temperature, T <sub>J</sub>		150	°C
Storage temperature, T <sub>stg</sub>	–65	150	°C

- (1) Stresses beyond those listed under *Absolute Maximum Ratings* may cause permanent damage to the device. These are stress ratings only, which do not imply functional operation of the device at these or any other conditions beyond those indicated under *Recommended Operating Conditions*. Exposure to absolute-maximum-rated conditions for extended periods may affect device reliability.
- (2) Short circuit to ground, one amplifier per package

### 6.2 ESD Ratings

		VALUE	UNIT
<b>OPA354A-Q1 IN DBV (SOT-23) PACKAGE AND OPA2354A-Q1 IN DGK (VSSOP) PACKAGE</b>			
V <sub>(ESD)</sub>	Electrostatic discharge	Human body model (HBM), per AEC Q100-002 <sup>(1)</sup>	±2000
		Charged device model (CDM), per AEC Q100-011	±1000
<b>OPA4354-Q1 IN PW (TSSOP) PACKAGE</b>			
V <sub>(ESD)</sub>	Electrostatic discharge	Human body model (HBM), per AEC Q100-002 <sup>(1)</sup>	±2000
		Charged device model (CDM), per AEC Q100-011	±250

- (1) AEC Q100-002 indicates HBM stressing is done in accordance with the ANSI/ESDA/JEDEC JS-001 specification.

### 6.3 Recommended Operating Conditions

over operating free-air temperature range (unless otherwise noted)

	MIN	MAX	UNIT
V <sub>S</sub> Supply voltage, V– to V+	2.5	5.5	V
T <sub>A</sub> Operating free-air temperature	–40	125	°C

### 6.4 Thermal Information: OPA354A-Q1

THERMAL METRIC <sup>(1)</sup>	OPA354A-Q1	OPA2354A-Q1	OPA4354-Q1	UNIT
	DBV (SOT-23)	DGK (VSSOP)	PW (TSSOP)	
	5 PINS	8 PINS	14 PINS	
R <sub>θJA</sub> Junction-to-ambient thermal resistance	216.3	175.9	92.6	°C/W
R <sub>θJC(top)</sub> Junction-to-case (top) thermal resistance	84.3	67.8	27.5	°C/W
R <sub>θJB</sub> Junction-to-board thermal resistance	43.1	97.1	33.6	°C/W
ψ <sub>JT</sub> Junction-to-top characterization parameter	3.8	9.3	1.9	°C/W
ψ <sub>JB</sub> Junction-to-board characterization parameter	42.3	95.5	33.1	°C/W
R <sub>θJC(bot)</sub> Junction-to-case (bottom) thermal resistance	N/A	N/A	N/A	°C/W

- (1) For more information about traditional and new thermal metrics, see the [Semiconductor and IC Package Thermal Metrics](#) application report.

## 6.5 Thermal Information: OPA2354A-Q1

THERMAL METRIC <sup>(1)</sup>		OPA2354A-Q1	
		DGK (VSSOP)	
		8 PINS	
			UNIT
$R_{\theta JA}$	Junction-to-ambient thermal resistance	175.9	°C/W
$R_{\theta JC(top)}$	Junction-to-case (top) thermal resistance	67.8	°C/W
$R_{\theta JB}$	Junction-to-board thermal resistance	97.1	°C/W
$\Psi_{JT}$	Junction-to-top characterization parameter	9.3	°C/W
$\Psi_{JB}$	Junction-to-board characterization parameter	95.5	°C/W
$R_{\theta JC(bot)}$	Junction-to-case (bottom) thermal resistance	N/A	°C/W

(1) For more information about traditional and new thermal metrics, see the [Semiconductor and IC Package Thermal Metrics](#) application report.

## 6.6 Thermal Information: OPA4354A-Q1

THERMAL METRIC <sup>(1)</sup>		OPA4354A-Q1	
		PW (TSSOP)	
		14 PINS	
			UNIT
$R_{\theta JA}$	Junction-to-ambient thermal resistance	92.6	°C/W
$R_{\theta JC(top)}$	Junction-to-case (top) thermal resistance	27.5	°C/W
$R_{\theta JB}$	Junction-to-board thermal resistance	33.6	°C/W
$\Psi_{JT}$	Junction-to-top characterization parameter	1.9	°C/W
$\Psi_{JB}$	Junction-to-board characterization parameter	33.1	°C/W
$R_{\theta JC(bot)}$	Junction-to-case (bottom) thermal resistance	N/A	°C/W

(1) For more information about traditional and new thermal metrics, see the [Semiconductor and IC Package Thermal Metrics](#) application report.

## 6.7 Electrical Characteristics

 $V_S = 2.5\text{ V to }5.5\text{ V}$ ,  $R_F$  (feedback resistor) = 0  $\Omega$ ,  $R_L$  (load resistor) = 1 k $\Omega$  connected to  $V_S / 2$  (unless otherwise noted)

PARAMETER		TEST CONDITIONS		MIN	TYP	MAX	UNIT
$V_{OS}$	Input offset voltage	$V_S = 5\text{ V}$ $V_{CM} = (V-) + 0.8\text{ V}$	$T_A = 25^\circ\text{C}$ $T_A = \text{Full range}$		$\pm 2$	$\pm 8$ $\pm 10$	mV
$\Delta V_{OS} / \Delta T$	Offset voltage drift over temperature	$T_A = \text{Full range}$			$\pm 4$		$\mu\text{V}/^\circ\text{C}$
PSRR	Offset voltage drift vs power supply	$V_S = 2.7\text{ V to }5.5\text{ V}$ , $V_{CM} = V_S / 2 - 0.15\text{ V}$	$T_A = 25^\circ\text{C}$ $T_A = \text{Full range}$		$\pm 200$	$\pm 800$ $\pm 900$	$\mu\text{V}/\text{V}$
$I_B$	Input bias current	$T_A = 25^\circ\text{C}$			3	$\pm 50$	pA
$I_{OS}$	Input offset current	$T_A = 25^\circ\text{C}$			$\pm 1$	$\pm 50$	pA
$V_n$	Input voltage noise density	$f = 1\text{ MHz}$ , $T_A = 25^\circ\text{C}$			6.5		$\text{nV}/\sqrt{\text{Hz}}$
$I_n$	Input current noise density	$f = 1\text{ MHz}$ , $T_A = 25^\circ\text{C}$			50		$\text{fA}/\sqrt{\text{Hz}}$
$V_{CM}$	Input common-mode voltage range	$T_A = 25^\circ\text{C}$		(V-) – 0.1		(V+) + 0.1	V
CMRR	Input common-mode rejection ratio	$V_S = 5.5\text{ V}$ $-0.1\text{ V} < V_{CM} < 3.5\text{ V}$	$T_A = 25^\circ\text{C}$	66	80	dB	
			$T_A = \text{Full range}$	64			
		$V_S = 5.5\text{ V}$ $-0.1\text{ V} < V_{CM} < 5.6\text{ V}$	$T_A = 25^\circ\text{C}$	56	68		
			$T_A = \text{Full range}$	55			
$Z_{ID}$	Differential input impedance	$T_A = 25^\circ\text{C}$			$10^{13} \parallel 2$	$\Omega \parallel \text{pF}$	
$Z_{ICM}$	Common-mode input impedance	$T_A = 25^\circ\text{C}$			$10^{13} \parallel 2$	$\Omega \parallel \text{pF}$	
$A_{OL}$	Open-loop gain	$V_S = 5\text{ V}$ , $0.3\text{ V} < V_O < 4.7\text{ V}$ $T_A = 25^\circ\text{C}$		94	110	dB	
		$V_S = 5\text{ V}$ , $0.4\text{ V} < V_O < 4.6\text{ V}$ $T_A = \text{Full range}$		90			
$f_{-3\text{dB}}$	Small-signal bandwidth	$G = 1$ , $V_O = 100\text{ mVp-p}$ , $R_F = 25\ \Omega$ , $T_A = 25^\circ\text{C}$			250	MHz	
		$G = 2$ , $V_O = 100\text{ mVp-p}$ , $T_A = 25^\circ\text{C}$			90		
GBW	Gain-bandwidth product	$G = 10$ $T_A = 25^\circ\text{C}$			100	MHz	
$f_{0.1\text{dB}}$	Bandwidth for 0.1-dB gain flatness	$G = 2$ , $V_O = 100\text{ mVp-p}$ , $T_A = 25^\circ\text{C}$			40	MHz	
SR	Slew rate	$V_S = 5\text{ V}$ , $G = 1$ , 4-V step, $T_A = 25^\circ\text{C}$			150	V/ $\mu\text{s}$	
		$V_S = 5\text{ V}$ , $G = 1$ , 2-V step			130		
		$V_S = 3\text{ V}$ , $G = 1$ , 2-V step			110		
$t_{\text{rf}}$	Rise-and-fall time	$G = 1$ , $V_O = 200\text{ mVp-p}$ , 10% to 90%, $T_A = 25^\circ\text{C}$			2	ns	
		$G = 1$ , $V_O = 2\text{ Vp-p}$ , 10% to 90%, $T_A = 25^\circ\text{C}$			11		
$t_{\text{settle}}$	Settling time	$V_S = 5\text{ V}$ , $G = +1$ , 2-V output step, $T_A = 25^\circ\text{C}$	0.1%		30	ns	
			0.01%		60		
	Overload recovery time	$V_{IN} \times \text{Gain} = V_S$ $T_A = 25^\circ\text{C}$			5	ns	
	Second-order harmonic distortion	$G = 1$ , $f = 1\text{ MHz}$ , $V_O = 2\text{ Vp-p}$ , $R_L = 200\ \Omega$ , $V_{CM} = 1.5\text{ V}$ $T_A = 25^\circ\text{C}$			-75	dBc	
	Third-order harmonic distortion	$G = 1$ , $f = 1\text{ MHz}$ , $V_O = 2\text{ Vp-p}$ , $R_L = 200\ \Omega$ , $V_{CM} = 1.5\text{ V}$ $T_A = 25^\circ\text{C}$			-83	dBc	
	Differential gain error	NTSC, $R_L = 150\ \Omega$ , $T_A = 25^\circ\text{C}$			0.02%		
	Differential phase error	NTSC, $R_L = 150\ \Omega$ , $T_A = 25^\circ\text{C}$			0.09	°	



**Electrical Characteristics (continued)**
 $V_S = 2.5\text{ V to }5.5\text{ V}$ ,  $R_F$  (feedback resistor) =  $0\ \Omega$ ,  $R_L$  (load resistor) =  $1\text{ k}\Omega$  connected to  $V_S / 2$  (unless otherwise noted)

PARAMETER	TEST CONDITIONS	MIN	TYP	MAX	UNIT
Channel-to-channel crosstalk (OPA2354A-Q1) (OPA4354-Q1)	$f = 5\text{ MHz}$ , $T_A = 25^\circ\text{C}$		-100		dB
Voltage output swing from rail	$V_S = 5\text{ V}$ , $R_L = 1\text{ k}\Omega$ , $A_{OL} > 94\text{ dB}$ $T_A = 25^\circ\text{C}$		0.1	0.3	V
	$V_S = 5\text{ V}$ , $R_L = 1\text{ k}\Omega$ $A_{OL} > 90\text{ dB}$ , $T_A = \text{Full range}$			0.4	
$I_O$ Output current <sup>(1)(2)</sup>	$V_S = 5\text{ V}$	100			mA
	$V_S = 3\text{ V}$		50		
Closed-loop output impedance	$f < 100\text{ kHz}$		0.05		$\Omega$
$R_O$ Open-loop output resistance			35		$\Omega$
$I_Q$ Quiescent current (per amplifier)	$V_S = 5\text{ V}$ , $I_O = 0$ , enabled	$T_A = 25^\circ\text{C}$	4.9	6	mA
		$T_A = \text{Full range}$		7.5	
Thermal shutdown junction temperature	Shutdown		160		$^\circ\text{C}$
	Reset from shutdown		140		

 (1) See typical characteristic graph *Output Voltage Swing vs Output Current* (图 20).

(2) Not production tested

## 6.8 Typical Characteristics

$T_A = 25^\circ\text{C}$ ,  $V_S = 5\text{ V}$ ,  $R_F = 0\ \Omega$ ,  $R_L = 1\ \text{k}\Omega$  connected to  $V_S / 2$  (unless otherwise noted)



图 1. Noninverting Small-Signal Frequency Response



图 2. Inverting Small-Signal Frequency Response

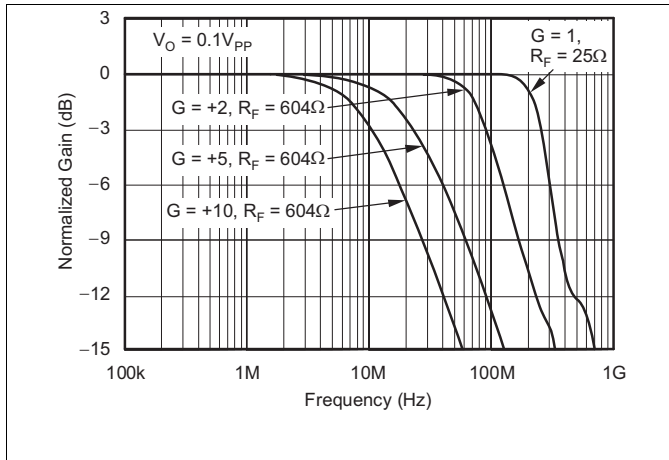

图 3. Noninverting Small-Signal Step Response

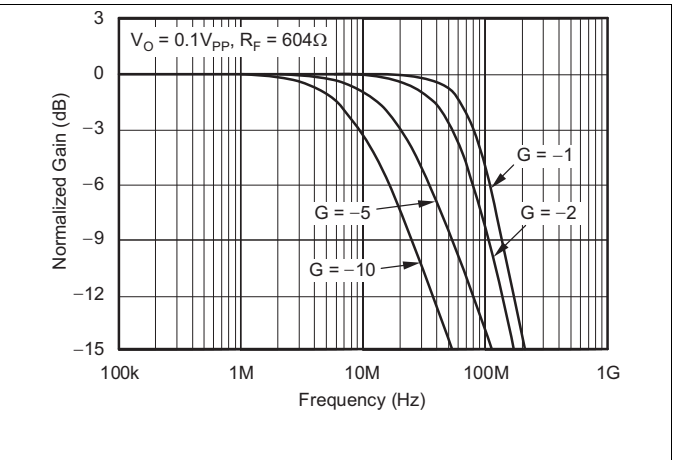

图 4. Noninverting Large-Signal Step Response

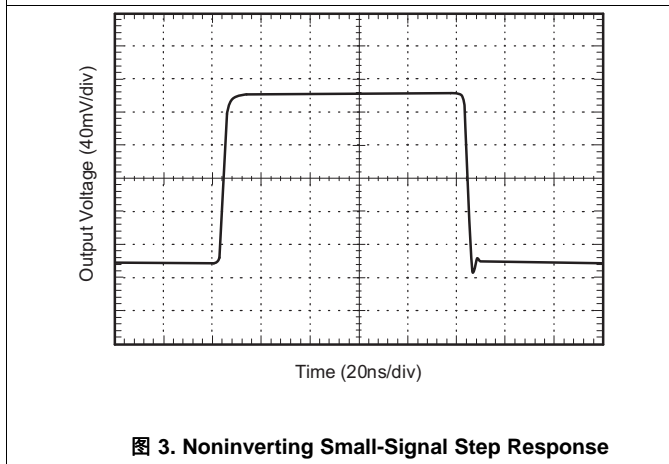

图 5. 0.1-dB Gain Flatness

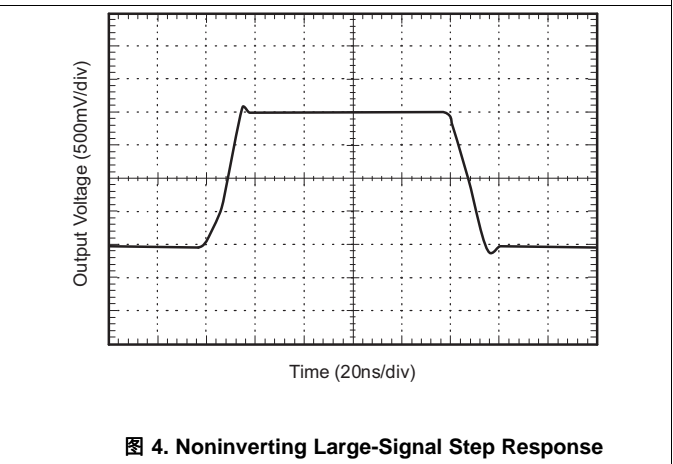

图 6. Harmonic Distortion vs Output Voltage

Typical Characteristics (接下页)

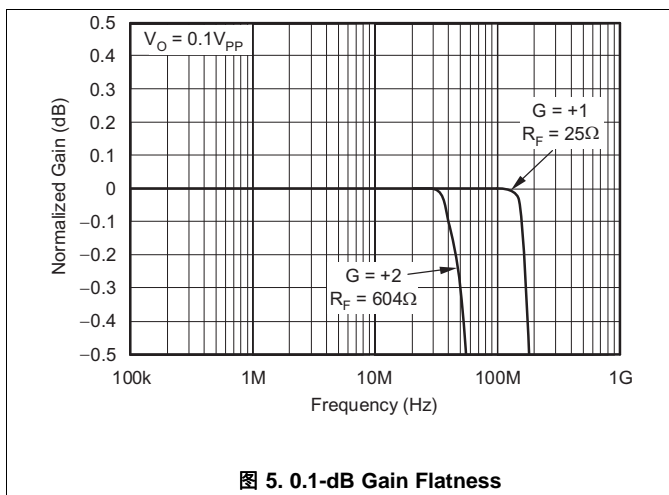
$T_A = 25^\circ\text{C}$ ,  $V_S = 5\text{ V}$ ,  $R_F = 0\ \Omega$ ,  $R_L = 1\text{ k}\Omega$  connected to  $V_S / 2$  (unless otherwise noted)

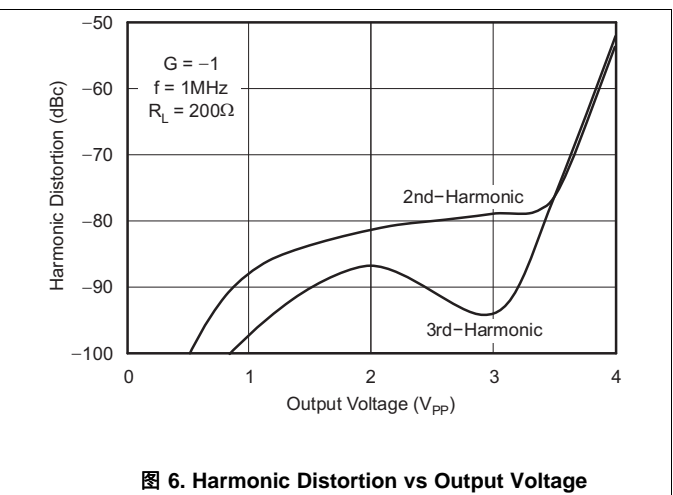
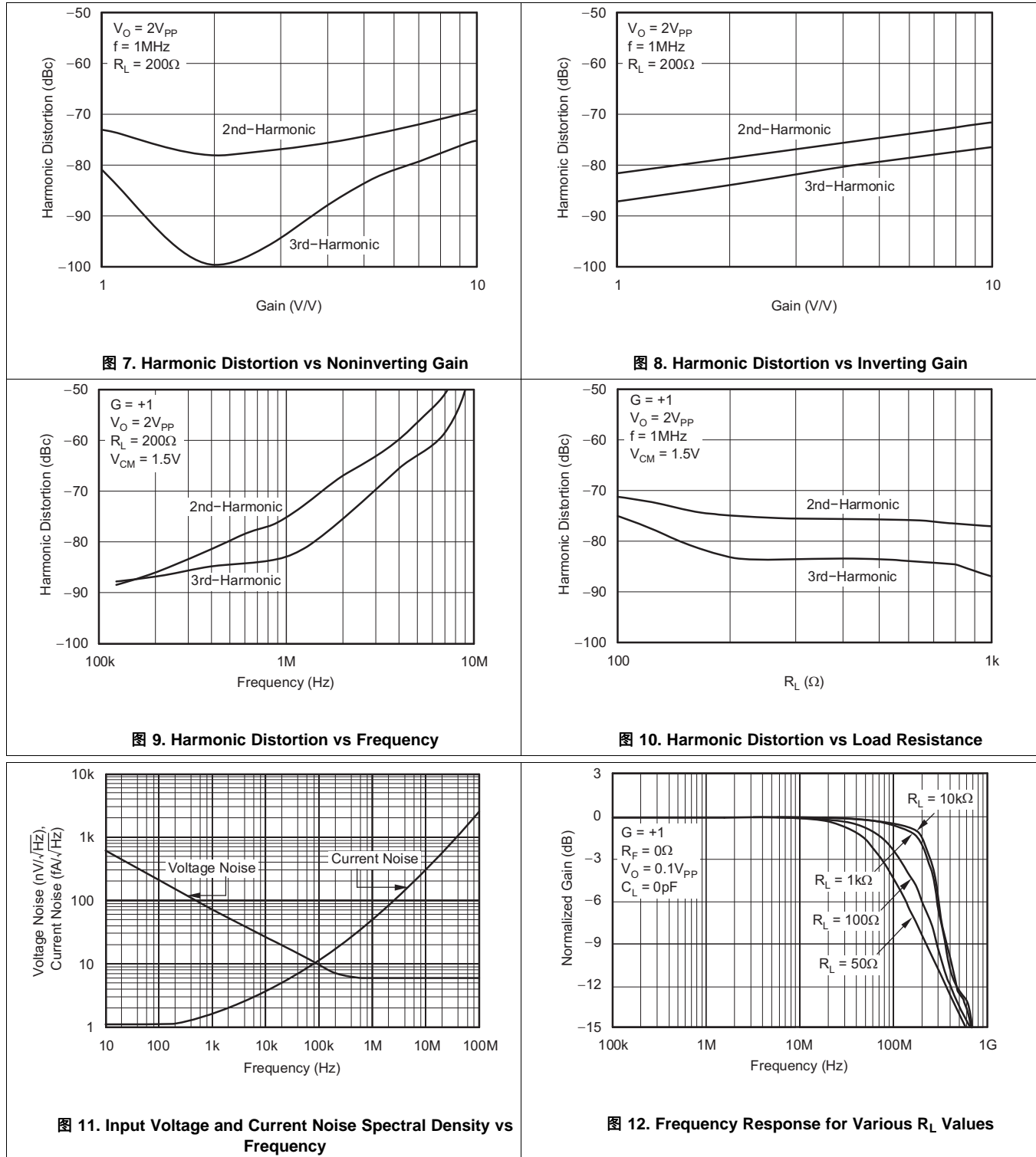

Typical Characteristics (接下页)

$T_A = 25^\circ\text{C}$ ,  $V_S = 5\text{ V}$ ,  $R_F = 0\ \Omega$ ,  $R_L = 1\ \text{k}\Omega$  connected to  $V_S / 2$  (unless otherwise noted)



图 13. Frequency Response for Various  $C_L$  Values



图 14. Recommended  $R_S$  vs Capacitive Load

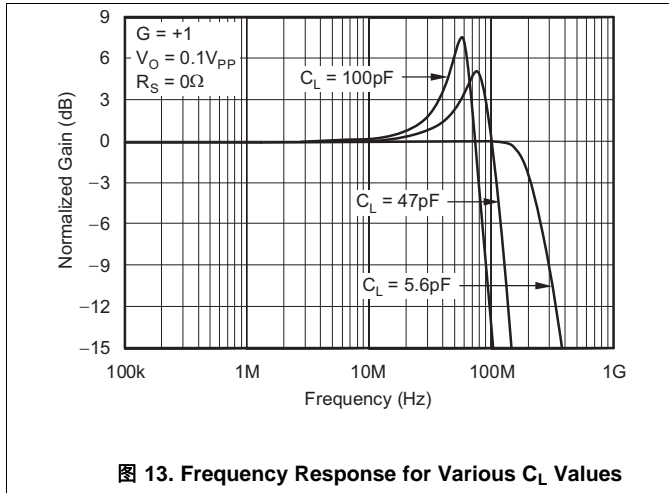

图 15. Frequency Response vs Capacitive Load

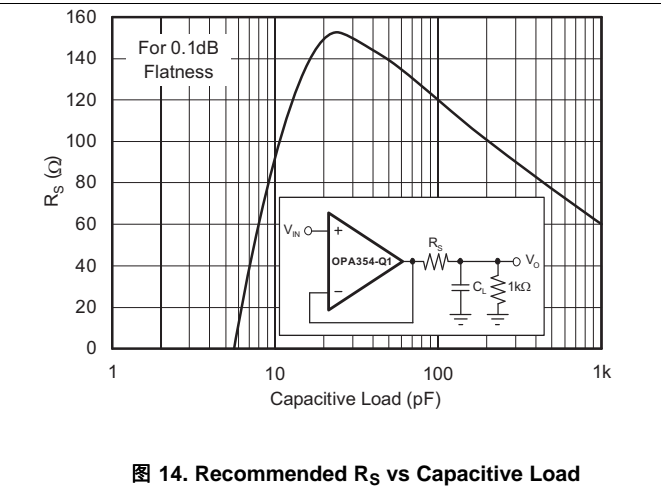

图 16. Common-Mode Rejection Ratio and Power-Supply Rejection Ratio vs Frequency

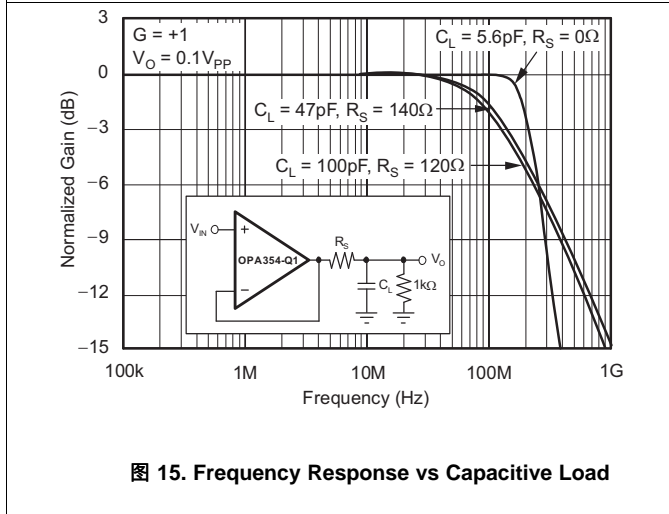

图 17. Open-Loop Gain and Phase

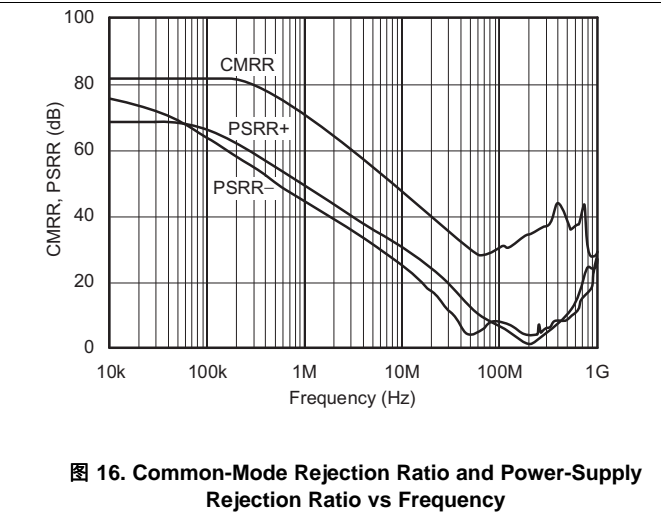

图 18. Composite Video Differential Gain and Phase

Typical Characteristics (接下页)

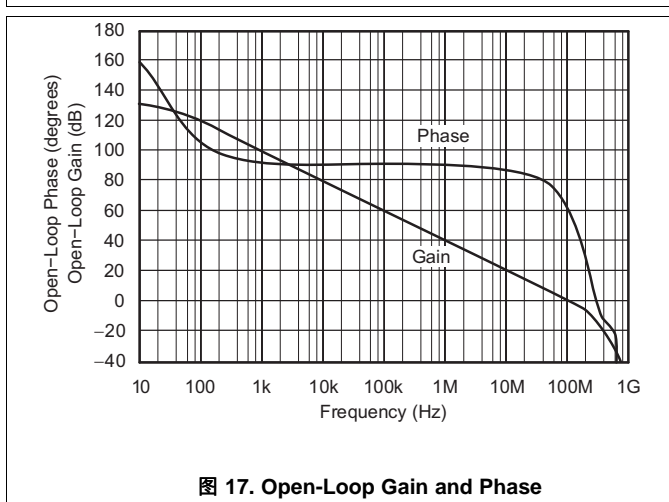
$T_A = 25^\circ\text{C}$ ,  $V_S = 5\text{ V}$ ,  $R_F = 0\ \Omega$ ,  $R_L = 1\ \text{k}\Omega$  connected to  $V_S / 2$  (unless otherwise noted)

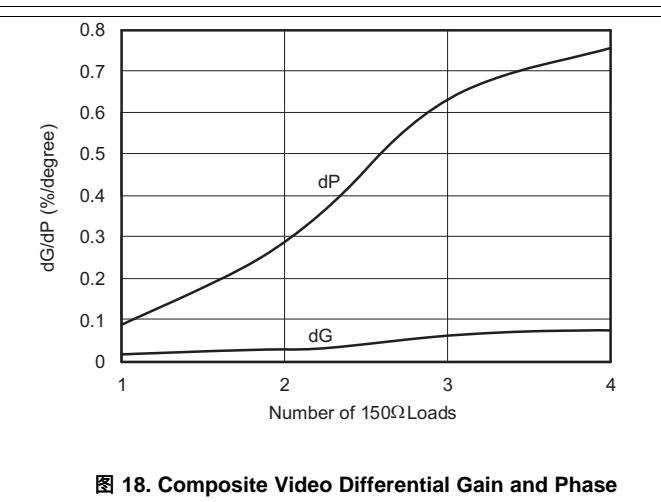

图 19. Input Bias Current vs Temperature



图 20. Output Voltage Swing vs Output Current

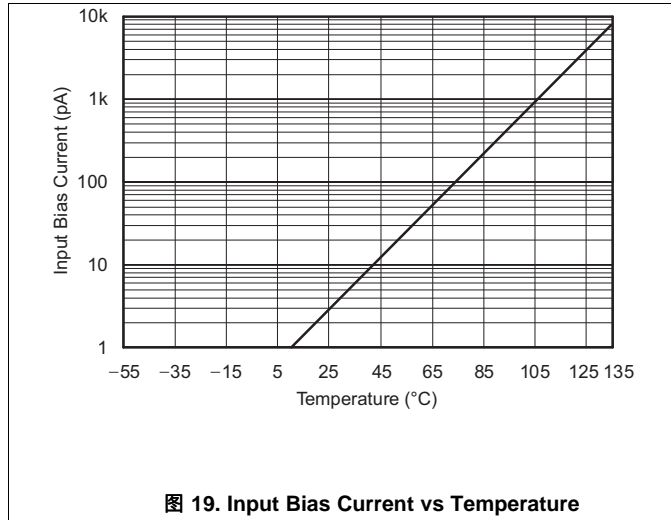

图 21. Supply Current vs Temperature

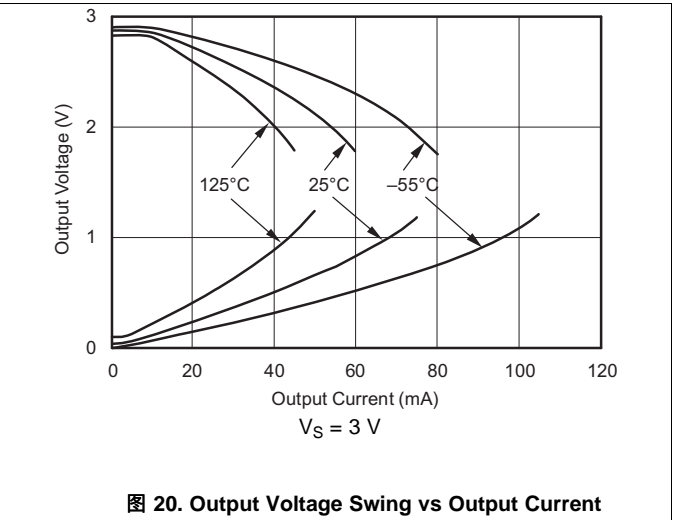

图 22. Output Voltage Swing vs Output Current

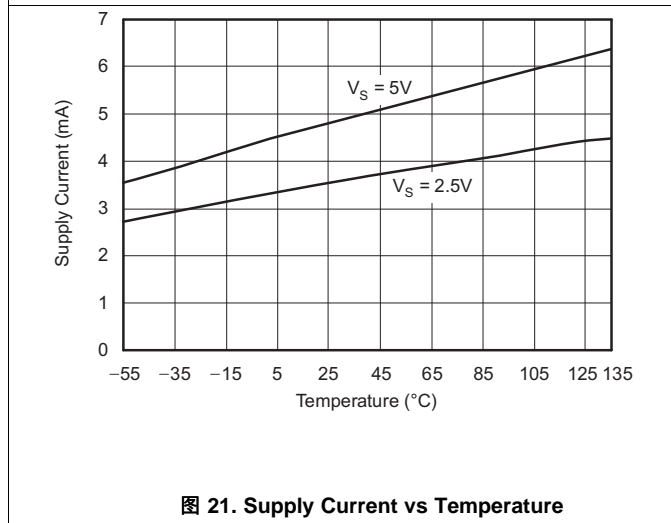

图 23. Closed-Loop Output Impedance vs Frequency

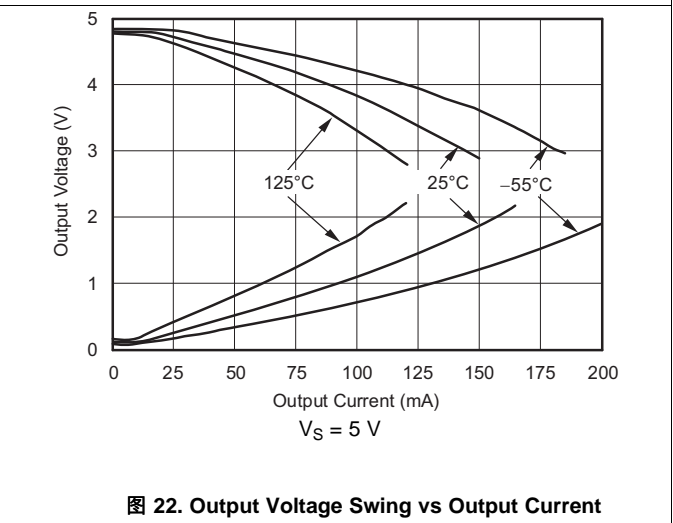

图 24. Maximum Output Voltage vs Frequency

Typical Characteristics (接下页)

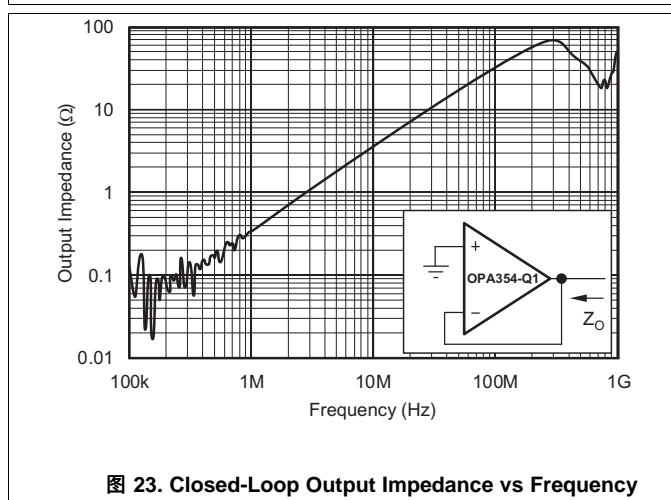
$T_A = 25^\circ\text{C}$ ,  $V_S = 5\text{ V}$ ,  $R_F = 0\ \Omega$ ,  $R_L = 1\text{ k}\Omega$  connected to  $V_S / 2$  (unless otherwise noted)

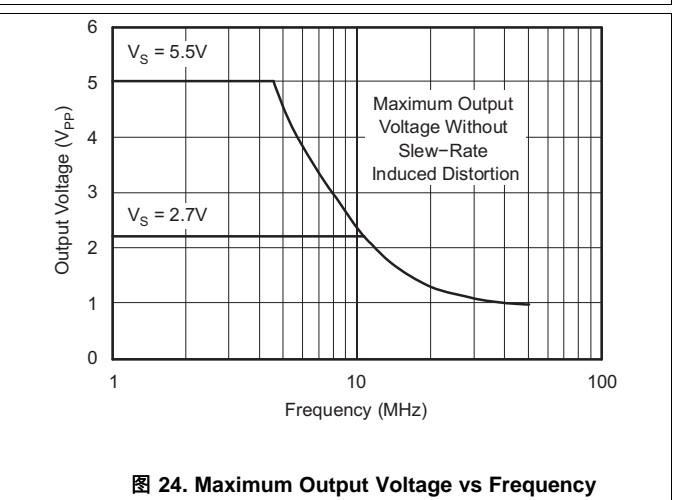

图 25. Output Settling Time to 0.1%



图 26. Open-Loop Gain vs Temperature

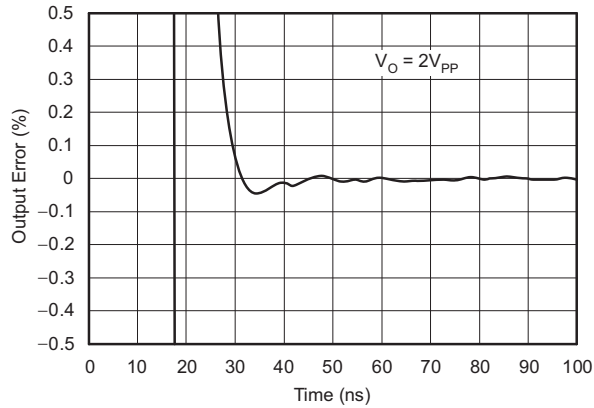

图 27. Offset Voltage Production Distribution

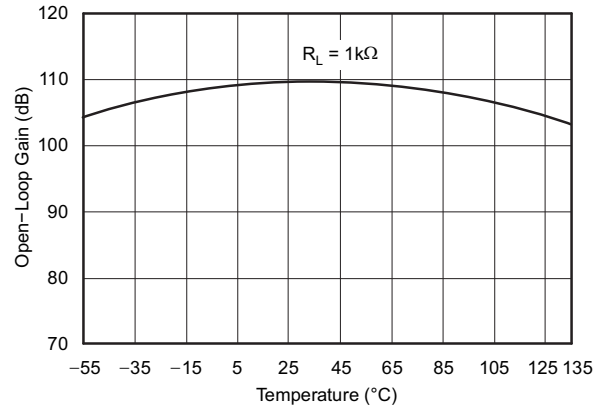

图 28. Common-Mode Rejection Ratio and Power-Supply Rejection Ratio vs Temperature

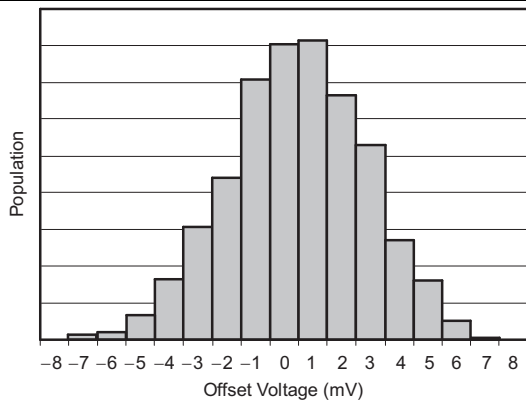

图 29. Channel-to-Channel Crosstalk (OPAx354-Q1)

## 7 Detailed Description

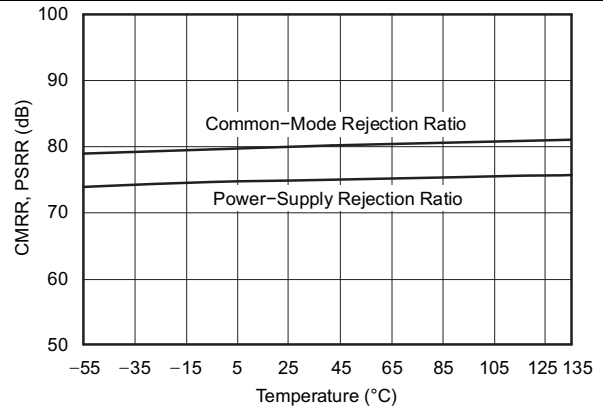
### 7.1 Overview

The OPAx354-Q1 operational amplifiers are high-speed, 150-V/ $\mu$ s, amplifiers making them excellent choices for transimpedance applications. The devices are unity-gain stable and can operate on a single-supply voltage (2.5 V to 5.5 V), or a split-supply voltage ( $\pm 1.25$  V to  $\pm 2.75$  V), making them highly versatile and easy to use. The OPAx354A-Q1 amplifiers are specified from 2.5 V to 5.5 V and over the automotive temperature range of  $-40^{\circ}\text{C}$  to  $+125^{\circ}\text{C}$ .

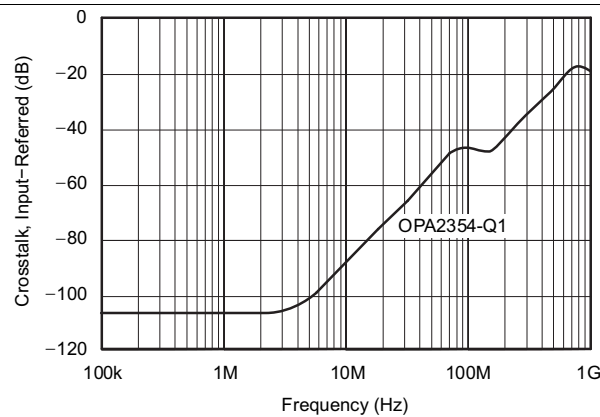
表 1. OPAx354-Q1 Related Products

FEATURES	PRODUCT
Shutdown Version of OPA354 Family	OPAx357
200-MHz GBW, Rail-to-Rail Output, CMOS, Shutdown	OPAx355
200-MHz GBW, Rail-to-Rail Output, CMOS	OPAx356
38-MHz GBW, Rail-to-Rail Input/Output, CMOS	OPAx350/3
75-MHz BW, G = 2, Rail-to-Rail Output	OPAx631
150-MHz BW, G = 2, Rail-to-Rail Output	OPAx634
100-MHz BW, Differential Input/Output, 3.3-V Supply	THS412x

### 7.2 Functional Block Diagram

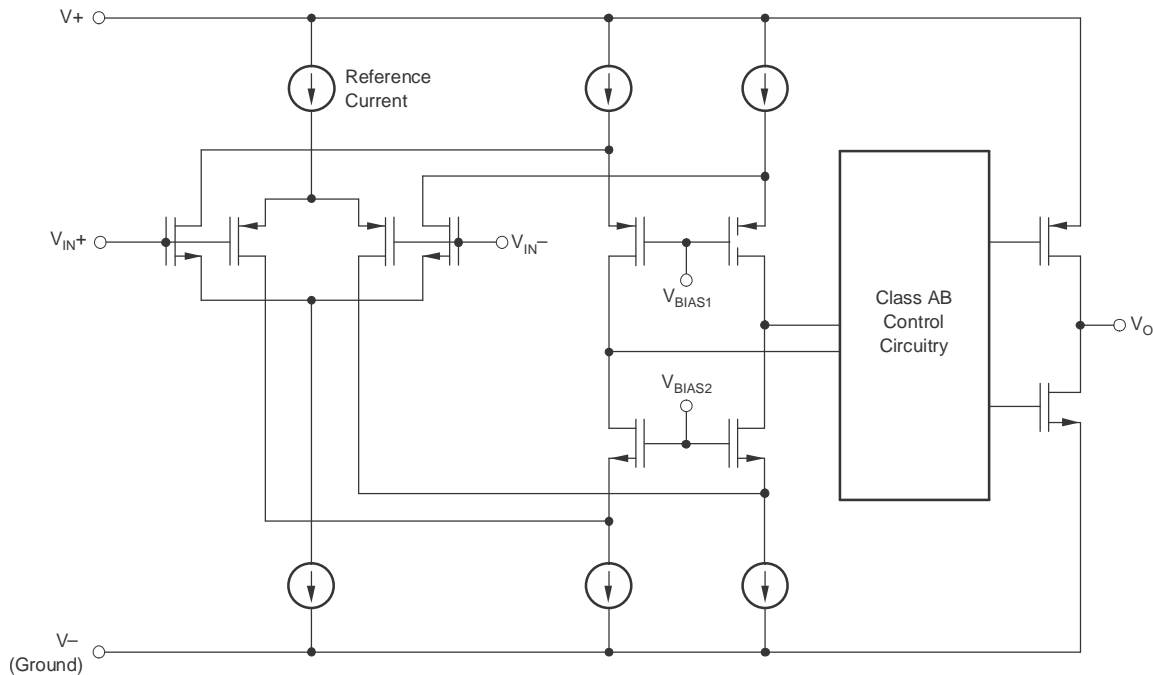

### 7.3 Feature Description

#### 7.3.1 Operating Voltage

The specifications of the OPAx354-Q1 family of devices apply over a power-supply range of 2.5 V to 5.5 V ( $\pm 1.25$  V to  $\pm 2.75$  V). Supply voltages higher than 7.5 V (absolute maximum) can permanently damage the amplifier.

The [Typical Characteristics](#) section of this data sheet shows the parameters that vary over supply voltage or temperature.

## Feature Description (接下页)

### 7.3.2 Rail-to-Rail Input

The specified input common-mode voltage range of the OPAx354-Q1 family of devices extends 100 mV beyond the supply rails. A complementary input stage (an N-channel input differential pair in parallel with a P-channel differential pair) achieves this extension. The N-channel pair is active for input voltages close to the positive rail, typically  $(V+) - 1.2\text{ V}$  to 100 mV above the positive supply, while the P-channel pair is on for inputs from 100 mV below the negative supply to approximately  $(V+) - 1.2\text{ V}$ . A small transition region exists, typically  $(V+) - 1.5\text{ V}$  to  $(V+) - 0.9\text{ V}$ , in which both pairs are on. This 600-mV transition region can vary  $\pm 500\text{ mV}$  with process variation. As a result, the transition region (both input stages on) range from  $(V+) - 2\text{ V}$  to  $(V+) - 1.5\text{ V}$  on the low end, up to  $(V+) - 0.9\text{ V}$  to  $(V+) - 0.4\text{ V}$  on the high end.

A double-folded cascode adds the signal from the two input pairs and presents a differential signal to the class-AB output stage.

### 7.3.3 Rail-to-Rail Output

The device uses a class-AB output stage with common-source transistors to achieve rail-to-rail output. For high-impedance loads ( $> 200\ \Omega$ ), the output voltage swing is typically 100 mV from the supply rails. With 10- $\Omega$  loads, a user can achieve a useful output swing while maintaining high open-loop gain; see [图 20](#) (*Output Voltage Swing vs Output Current*).

### 7.3.4 Output Drive

The OPAx354-Q1 output stage supplies a continuous output current of  $\pm 100\text{ mA}$  and still provide approximately 2.7-V output swing on a 5-V supply, as shown in [图 30](#).

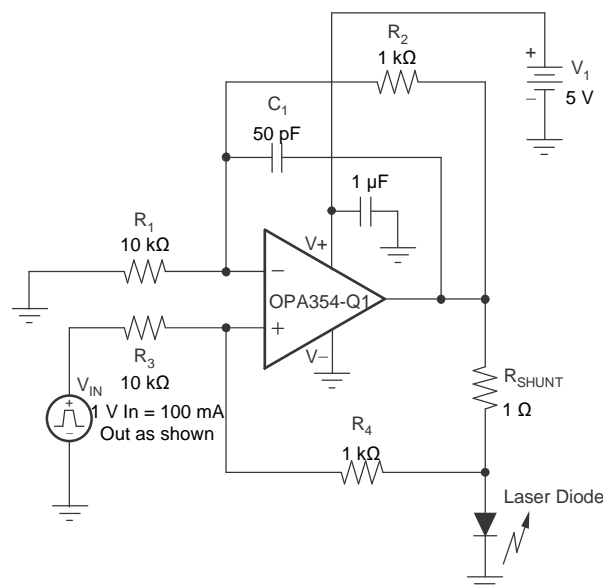

**图 30. Laser Diode Driver**

For maximum reliability, TI does not recommend running a continuous DC current greater than  $\pm 100\text{ mA}$ ; see [图 20](#) (*Output Voltage Swing vs Output Current*). Operate the OPAx354-Q1 family of devices in parallel to supply continuous output currents greater than  $\pm 100\text{ mA}$ , as shown in [图 31](#).



Feature Description (接下页)



图 31. Parallel Operation

The OPAx354-Q1 family of devices provides peak currents up to 200 mA, which correspond to the typical short-circuit current. Therefore, an on-chip thermal shutdown circuit protects the OPAx354-Q1 family of devices from dangerously high junction temperatures. At 160°C, the protection circuit shuts down the amplifier. Normal operation resumes when the junction temperature cools below 140°C.

7.3.5 Video

The OPAx354-Q1 output stage is capable of driving standard back-terminated 75-Ω video cables (see 图 32). A back-terminated transmission line does not exhibit a capacitive load to the driver. A properly back-terminated 75-Ω cable does not appear as capacitance; the cable presents a 150-Ω resistive load to the OPAx354-Q1 output.

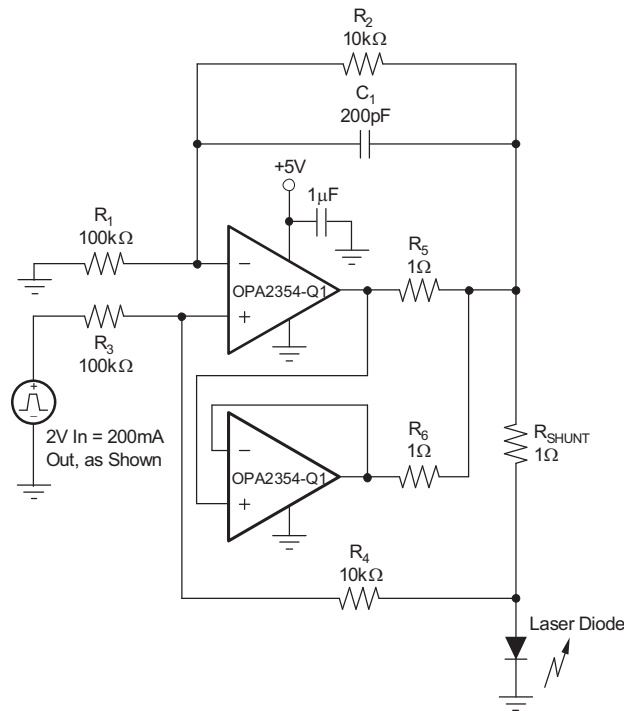

图 32. Single-Supply Video Line Driver

This series of amplifiers can be used as an amplifier for RGB graphic signals, which have a voltage of zero at the video black level by offsetting and AC-coupling the signal (see 图 33).

**Feature Description (接下页)**

(1) Source video signal offset 300 mV above ground to accommodate op amp swing to ground capability.

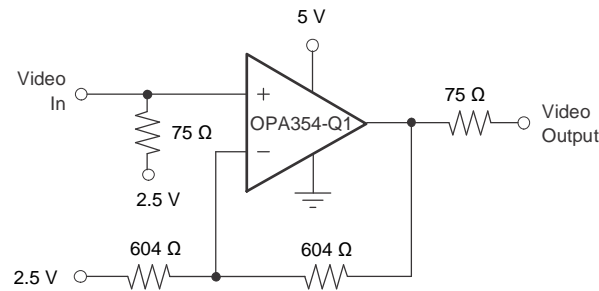
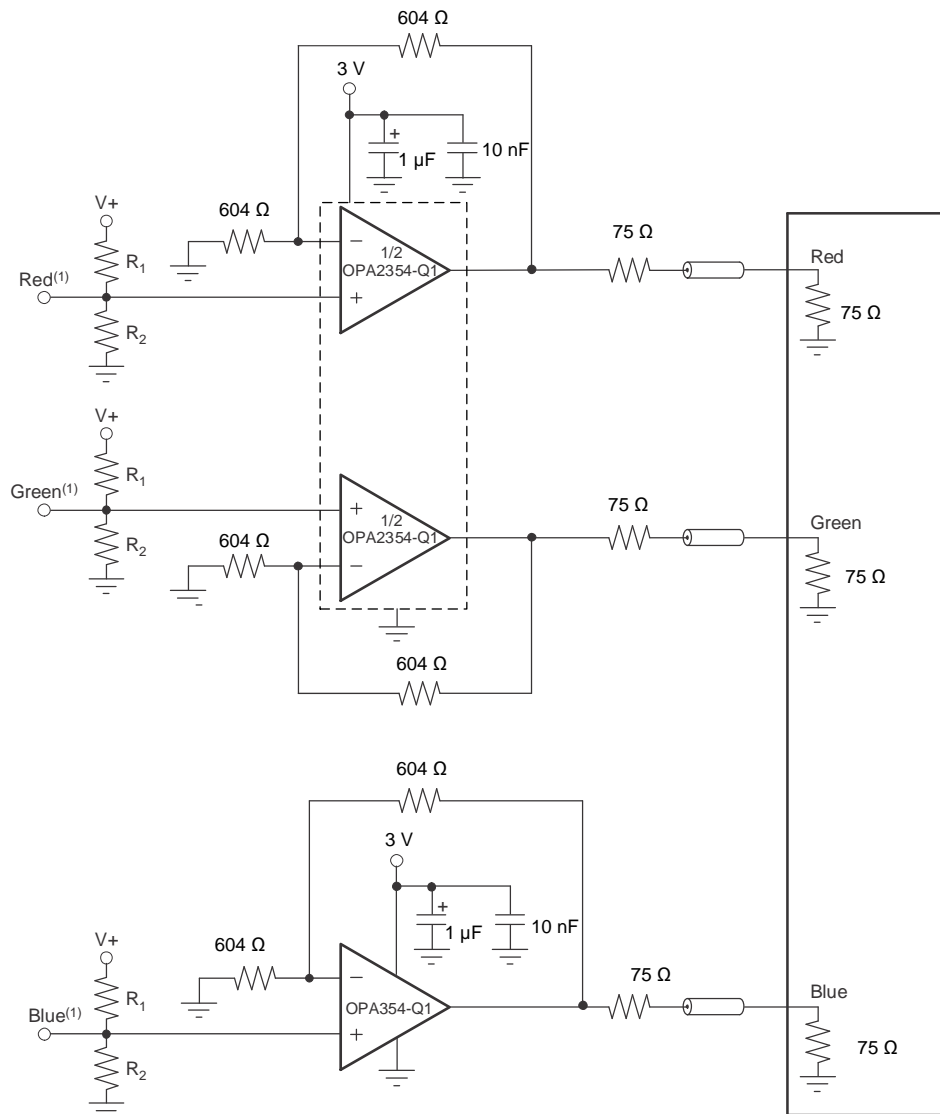
**图 33. RGB Cable Driver**

**7.3.6 Driving Analog-to-Digital Converters**

The OPAx354-Q1 family of op-amps offers a 60-ns settling time to 0.01%, which makes the devices a viable option for driving high- and medium-speed sampling ADCs and reference circuits. The OPAx354-Q1 family of devices provides an effective means of buffering the input capacitance and resulting charge injection of the ADC while providing signal gain. The OPAx354-Q1 family of devices is designed for applications requiring high DC accuracy.

图 34 shows the OPAx354-Q1 family of devices driving an ADC. With the OPAx354-Q1 family of devices in an inverting configuration, using a capacitor across the feedback resistor can filter high-frequency noise in the signal.

## Feature Description (接下页)



图 34. OPA354A-Q1 Inverting Configuration Driving the ADS7816

### 7.3.7 Capacitive Load and Stability

The OPAx354-Q1 family op amps can drive a wide range of capacitive loads. However, all op-amps under certain conditions can become unstable. Op amp configuration, gain, and load value are a few of the factors to consider when determining stability. An op amp in unity-gain configuration is most susceptible to the effects of capacitive loading. The capacitive load reacts with the output resistance of the op amp, along with any additional load resistance, to create a pole in the small-signal response that degrades the phase margin. For details, see 图 15 (*Frequency Response vs Capacitive Load*.)

The OPAx354-Q1 topology enhances the ability of the device to drive capacitive loads. In unity gain, these op-amps perform well with large capacitive loads. For details see 图 14, Recommended  $R_S$  vs *Capacitive Load*, and 图 15, *Frequency Response vs Capacitive Load*.

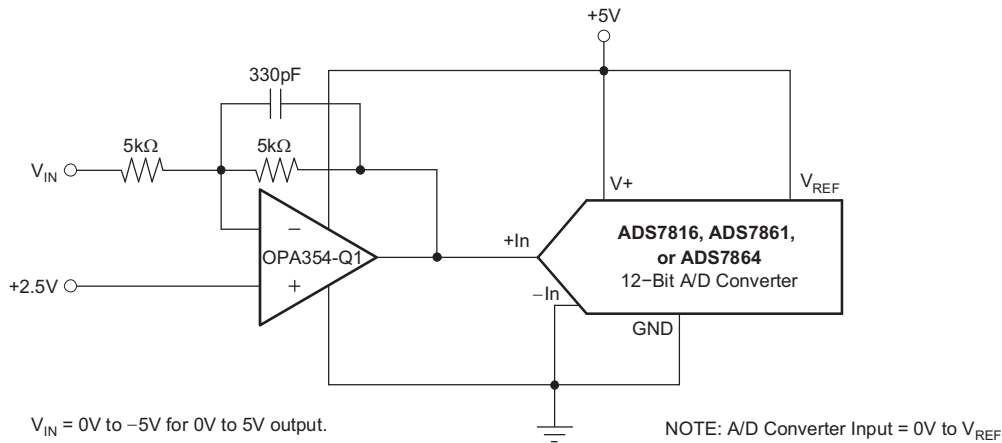
Insert a 10- $\Omega$  to 20- $\Omega$  resistor in series with the output to improve capacitive load drive in the unity-gain configuration, as shown in 图 35. This configuration significantly reduces ringing with large capacitive loads; see 图 15 (*Frequency Response vs Capacitive Load*.) However, if a resistive load is in parallel with the capacitive load,  $R_S$  creates a voltage divider. This configuration introduces a DC error at the output and slightly reduces output swing. This error may be insignificant. For example, if  $R_L = 10\text{ k}\Omega$  and  $R_S = 20\ \Omega$ , the error at the output is approximately 0.2%.



图 35. Series Resistor in Unity-Gain Configuration Improves Capacitive Load Drive

### 7.3.8 Wideband Transimpedance Amplifier

Wide bandwidth, low-input bias current, and low input voltage and current noise make the OPAx354-Q1 family of devices is designed as a wideband photodiode transimpedance amplifier for low-voltage single-supply applications. Low-voltage noise is important because photodiode capacitance causes the effective noise gain of the circuit to increase at high frequency.

## Feature Description (接下页)

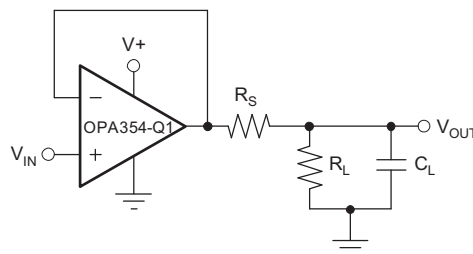
The key elements to a transimpedance design, as shown in 图 36, are the expected diode capacitance [including the parasitic input common-mode and differential-mode input capacitance (2 + 2) pF for the OPAx354-Q1], the desired transimpedance gain ( $R_F$ ), and the gain-bandwidth product (GBW) for the OPAx354-Q1 family of devices (100 MHz). With these three variables set, the feedback capacitor value ( $C_F$ ) is set to control the frequency response.



图 36. Transimpedance Amplifier

To achieve a maximally flat second-order Butterworth frequency response, set the feedback pole as shown in 公式 1.

$$\frac{1}{2\pi R_F C_F} = \sqrt{\frac{\text{GBP}}{4\pi R_F C_D}} \quad (1)$$

Typical surface-mount resistors have a parasitic capacitance of approximately 0.2 pF that required deduction from the calculated feedback capacitance value.

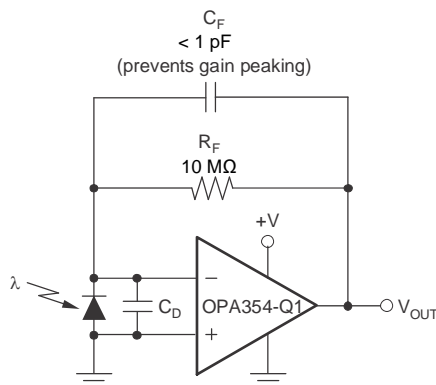
Use 公式 2 to calculate the bandwidth.

$$f_{-3\text{dB}} = \sqrt{\frac{\text{GBP}}{2\pi R_F C_D}} \text{ Hz} \quad (2)$$

For even higher transimpedance bandwidth, use the high-speed CMOS OPA355-Q1 (200-MHz GBW) or the OPA655-Q1 (400-MHz GBW).

## 7.4 Device Functional Modes

The OPAx354-Q1 family of devices is powered on when the supply is connected. The devices operates as a single-supply operational amplifier or dual-supply amplifier depending on the application. The devices are used with asymmetrical supplies as long as the differential voltage ( $V_-$  to  $V_+$ ) is at least 1.8 V and no greater than 5.5 V (example:  $V_-$  set to  $-3.5$  V and  $V_+$  set to 1.5 V).

## 8 Application and Implementation

### 注

Information in the following applications sections is not part of the TI component specification, and TI does not warrant its accuracy or completeness. TI's customers are responsible for determining suitability of components for their purposes. Customers should validate and test their design implementation to confirm system functionality.

### 8.1 Application Information

The OPAx354-Q1 family of devices is a CMOS, rail-to-rail I/O, high-speed, voltage-feedback operational amplifier designed for video, high-speed, and other applications. The OPAx354-Q1 family of devices is available as a single, dual, or quad op-amp.

The amplifier features a 100-MHz gain bandwidth, and 150 V/ $\mu$ s slew rate, but the device is unity-gain stable and operates as a 1-V/V voltage follower.

### 8.2 Typical Applications

#### 8.2.1 Transimpedance Amplifier

Wide gain bandwidth, low input bias current, low input voltage, and current noise make the OPAx354-Q1 family of devices a preferred wideband photodiode transimpedance amplifier. Low-voltage noise is important because photodiode capacitance causes the effective noise gain of the circuit to increase at high frequency.

The key elements to a transimpedance design, as shown in 图 37, are the expected diode capacitance ( $C_{(D)}$ ), which must include the parasitic input common-mode and differential-mode input capacitance (4 pF + 5 pF); the desired transimpedance gain ( $R_{(FB)}$ ); and the gain-bandwidth (GBW) for the OPAx354-Q1 family of devices (20 MHz). With these three variables set, the feedback capacitor value ( $C_{(FB)}$ ) is set to control the frequency response.  $C_{(FB)}$  includes the stray capacitance of  $R_{(FB)}$ , which is 0.2 pF for a typical surface-mount resistor.

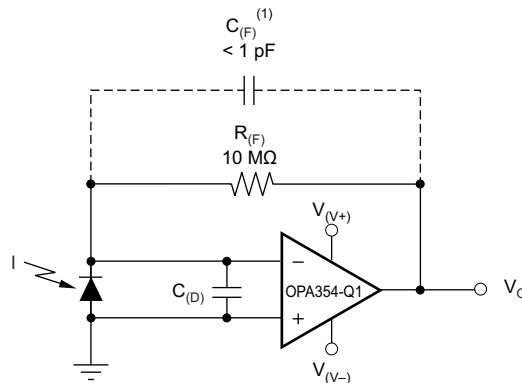

(1)  $C_{(FB)}$  is optional to prevent gain peaking.  $C_{(FB)}$  includes the stray capacitance of  $R_{(FB)}$ .

图 37. Dual-Supply Transimpedance Amplifier

#### 8.2.1.1 Design Requirements

PARAMETER	VALUE
Supply voltage $V_{(V+)}$	2.5 V
Supply voltage $V_{(V-)}$	-2.5 V

#### 8.2.1.2 Detailed Design Procedure

To achieve a maximally-flat, second-order Butterworth frequency response, the feedback pole must be set to:

$$\frac{1}{2 \times \pi \times R_{(FB)} \times C_{(FB)}} = \sqrt{\frac{\text{GBW}}{4 \times \pi \times R_{(FB)} \times C_{(D)}}} \quad (3)$$

Use [公式 4](#) to calculate the bandwidth.

$$f_{(-3 \text{ dB})} = \sqrt{\frac{\text{GBW}}{2 \times \pi \times R_{(\text{FB})} \times C_{(\text{D})}}} \quad (4)$$

For other transimpedance bandwidths, consider the high-speed CMOS [OPA380](#) (90-MHz GBW), [OPA354](#) (100-MHz GBW), [OPA300](#) (180-MHz GBW), [OPA355](#) (200-MHz GBW), or [OPA656](#) and [OPA657](#) (400-MHz GBW).

For single-supply applications, the +INx input can be biased with a positive DC voltage to allow the output to reach true zero when the photodiode is not exposed to any light, and respond without the added delay that results from coming out of the negative rail; this configuration is shown in [图 38](#). This bias voltage appears across the photodiode, providing a reverse bias for faster operation.

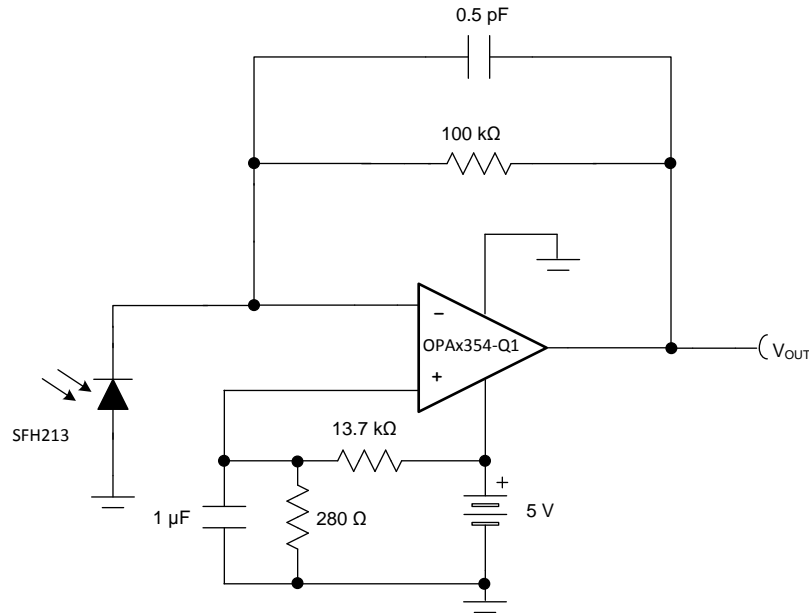

**图 38. Single-Supply Transimpedance Amplifier**

For additional information, see the [Compensate Transimpedance Amplifiers Intuitively](#) application bulletin.

#### 8.2.1.2.1 Optimizing The Transimpedance Circuit

To achieve the best performance, components must be selected according to the following guidelines:

1. For lowest noise, select  $R_{(\text{FB})}$  to create the total required gain. Using a lower value for  $R_{(\text{FB})}$  and adding gain after the transimpedance amplifier generally produces poorer noise performance. The noise produced by  $R_{(\text{FB})}$  increases with the square-root of  $R_{(\text{FB})}$ , whereas the signal increases linearly. Therefore, signal-to-noise ratio improves when all the required gain is placed in the transimpedance stage.
2. Minimize photodiode capacitance and stray capacitance at the summing junction (inverting input). This capacitance causes the voltage noise of the op amp to be amplified (increasing amplification at high frequency). Using a low-noise voltage source to reverse-bias a photodiode can significantly reduce the capacitance. Smaller photodiodes have lower capacitance. Use optics to concentrate light on a small photodiode.
3. Noise increases with increased bandwidth. Limit the circuit bandwidth to only that required. Use a capacitor across the  $R_{(\text{FB})}$  to limit bandwidth, even if not required for stability.
4. Circuit board leakage can degrade the performance of an otherwise well-designed amplifier. Clean the circuit board carefully. A circuit board guard trace that encircles the summing junction and is driven at the same voltage can help control leakage.

For additional information, see the [Noise Analysis of FET Transimpedance Amplifiers](#), and [Noise Analysis for High-Speed Op Amps](#) application bulletins.

### 8.2.1.3 Application Curve

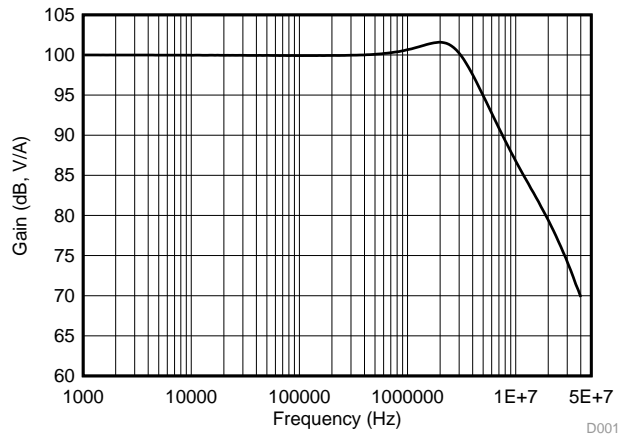

–3 dB bandwidth is 4.56 MHz

图 39. AC Transfer Function

### 8.2.2 High-Impedance Sensor Interface

Many sensors have high source impedances that may range up to 10 MΩ, or even higher. The output signal of sensors often must be amplified or otherwise conditioned by an amplifier. The input bias current of this amplifier can load the sensor output and cause a voltage drop across the source resistance, as shown in 图 40, where  $(V_{(+INx)} = V_S - I_{(BIAS)} \times R_{(S)})$ . The last term,  $I_{(BIAS)} \times R_{(S)}$ , shows the voltage drop across  $R_{(S)}$ . To prevent errors introduced to the system as a result of this voltage, use an op amp with low input bias current and high-impedance sensors. This low current keeps the error contribution by  $I_{(BIAS)} \times R_{(S)}$  less than the input voltage noise of the amplifier, so that the amplifier does not become the dominant noise factor. The OPAX354-Q1 family of devices series of op amps feature low input bias current (typically 200 fA), and are therefore designed for such applications.



图 40. Noise as a Result of  $I_{(BIAS)}$

### 8.2.3 Driving ADCs

The OPAX354-Q1 op amps are designed for driving sampling analog-to-digital converters (ADCs) with sampling speeds up to 1 MSPS. The zero-crossover distortion input stage topology allows the OPAX354-Q1 family of devices to drive ADCs without degradation of differential linearity and THD.

The OPAX354-Q1 family of devices can be used to buffer the ADC switched input capacitance and resulting charge injection while providing signal gain. [Figure 41](#) shows the OPAX354-Q1 family of devices configured to drive the [ADS8326](#).

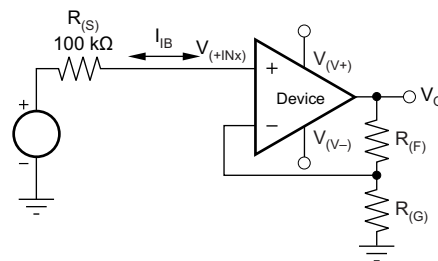
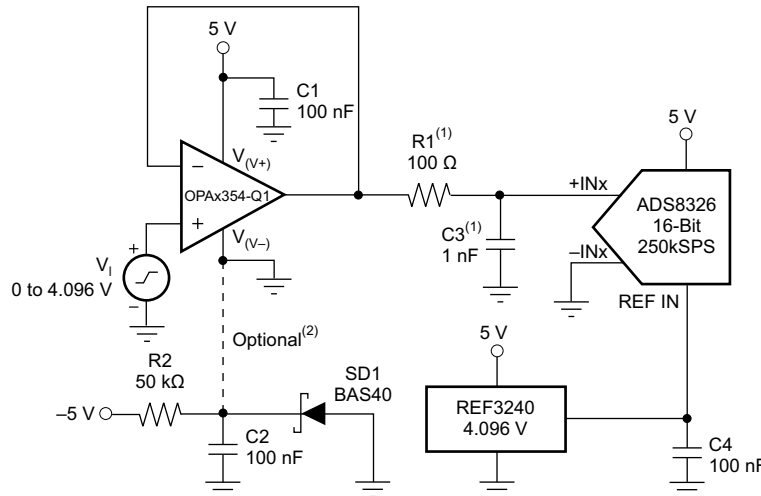

(1) Suggested value; may require adjustment based on specific application.

(2) Single-supply applications lose a small number of ADC codes near ground as a result of op amp output swing limitation. If a negative power supply is available, this simple circuit creates a  $-0.3\text{-V}$  supply to allow output swing to true ground potential.

**图 41. Driving the ADS8326**

### 8.2.4 Active Filter

The OPAX354-Q1 family of devices is designed for active filter applications that require a wide bandwidth, fast slew rate, low-noise, single-supply operational amplifier. [Figure 42](#) shows a 500 kHz, second-order, low-pass filter using the multiple-feedback (MFB) topology. The components are selected to provide a maximally-flat Butterworth response. Beyond the cutoff frequency, roll-off is  $-40\text{ dB/dec}$ . The Butterworth response is designed for applications requiring predictable gain characteristics, such as the anti-aliasing filter used in front of an ADC.

One point to observe when considering the MFB filter is that the output is inverted relative to the input. If this inversion is not required, or not desired, a noninverting output can be achieved through one of the following options:

1. Adding an inverting amplifier
2. Adding an additional second-order MFB stage
3. Using a noninverting filter topology, such as the Sallen-Key (see [Figure 43](#)).

MFB and Sallen-Key, low-pass and high-pass filter synthesis is accomplished using TI's [FilterPro™](#) program. This software is available as a free download on [www.ti.com](http://www.ti.com).





图 42. Second-Order Butterworth 500-kHz Low-Pass Filter



图 43. OPAx354-Q1 Configured as a Three-Pole, 20-kHz, Sallen-Key Filter

## 9 Power Supply Recommendations

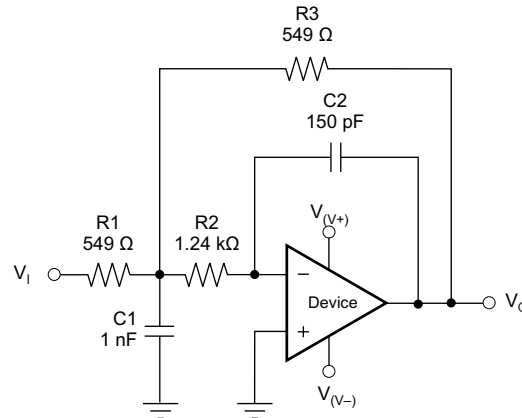
The OPAx354-Q1 family of devices is specified for operation from 2.5 to 5.5 V ( $\pm 1.25$  to  $\pm 2.75$  V); many specifications apply from  $-40^{\circ}\text{C}$  to  $+125^{\circ}\text{C}$ . Parameters that can exhibit significant variance with regard to operating voltage or temperature are shown in the [Typical Characteristics](#) section.

### CAUTION

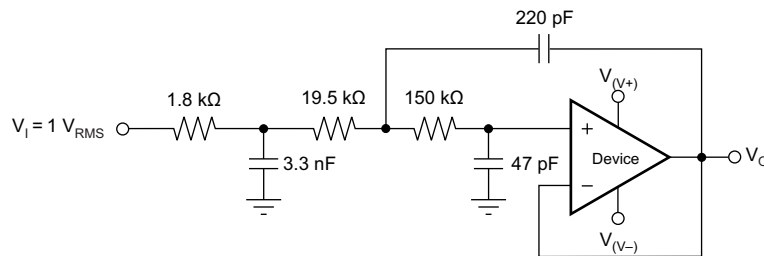
Supply voltages larger than 7.5 V can permanently damage the device (see the [Absolute Maximum Ratings](#) table).

Place 0.1- $\mu\text{F}$  bypass capacitors close to the power-supply pins to reduce errors coupling in from noisy or high-impedance power supplies. For more detailed information on bypass capacitor placement, see the [Layout Guidelines](#) section.

## 9.1 Power Dissipation

Power dissipation depends on power-supply voltage, signal and load conditions. With dc signals, power dissipation is equal to the product of output current times the voltage across the conducting output transistor ( $V_S - V_O$ ). Minimize power dissipation by using the lowest possible power-supply voltage required to ensure the required output voltage swing.

For resistive loads, the maximum power dissipation occurs at a DC output voltage of one-half the power-supply voltage. Dissipation with AC signals is lower. The [Power Amplifier Stress and Power Handling Limitations](#) application bulletin from [www.ti.com](http://www.ti.com) explains how to calculate or measure power dissipation with unusual signals and loads.

Any tendency to activate the thermal protection circuit indicates excessive power dissipation or an inadequate heat sink. For reliable operation, limit junction temperature to 150°C, maximum. To estimate the margin of safety in a complete design, increase the ambient temperature to trigger the thermal protection at 160°C. The thermal protection must trigger more than 35°C above the maximum expected ambient condition of the application.

## 10 Layout

### 10.1 Layout Guidelines

Use good high-frequency printed circuit board (PCB) layout techniques for the OPAx354-Q1 family of devices. Generous use of ground planes, short and direct signal traces, and a suitable bypass capacitor located at the V+ pin ensure clean, stable operation. Large areas of copper provide a means of dissipating heat that is generated in normal operation. Sockets are not recommended for use with any high-speed amplifier. A 10-nF ceramic bypass capacitor is the minimum recommended value; adding a 1- $\mu$ F or larger tantalum capacitor in parallel can be beneficial when driving a low-resistance load. Providing adequate bypass capacitance is essential to achieving very low harmonic and intermodulation distortion.

For best operational performance of the device, use good PCB layout practices, including:

- Noise can propagate into analog circuitry through the power pins of the circuit as a whole and the operational amplifier. Bypass capacitors are used to reduce the coupled noise by providing low-impedance power sources local to the analog circuitry.
  - Connect low-ESR, 0.1- $\mu$ F ceramic bypass capacitors between each supply pin and ground, placed as close to the device as possible. A single bypass capacitor from V+ to ground is applicable for single-supply applications.
- Separate grounding for analog and digital portions of the circuitry is one of the simplest and most effective methods of noise suppression. One or more layers on multilayer PCBs are usually devoted to ground planes. A ground plane helps distribute heat and reduces EMI noise pickup. Make sure to physically separate digital and analog grounds, paying attention to the flow of the ground current. For more detailed information, see [Circuit Board Layout Techniques](#).
- To reduce parasitic coupling, run the input traces as far away from the supply or output traces as possible. If these traces cannot be kept separate, crossing the sensitive trace perpendicularly is much better than crossing in parallel with the noisy trace.
- Place the external components as close to the device as possible. Keeping RF and RG close to the inverting input minimizes parasitic capacitance, as shown in [图 44](#).
- Keep the length of input traces as short as possible. Always remember that the input traces are the most sensitive part of the circuit.
- Consider a driven, low-impedance guard ring around the critical traces. A guard ring can significantly reduce leakage currents from nearby traces that are at different potentials.

## 10.2 Layout Example



图 44. Operational Amplifier Board Layout for Noninverting Configuration

## 11 器件和文档支持

### 11.1 文档支持

#### 11.1.1 相关文档

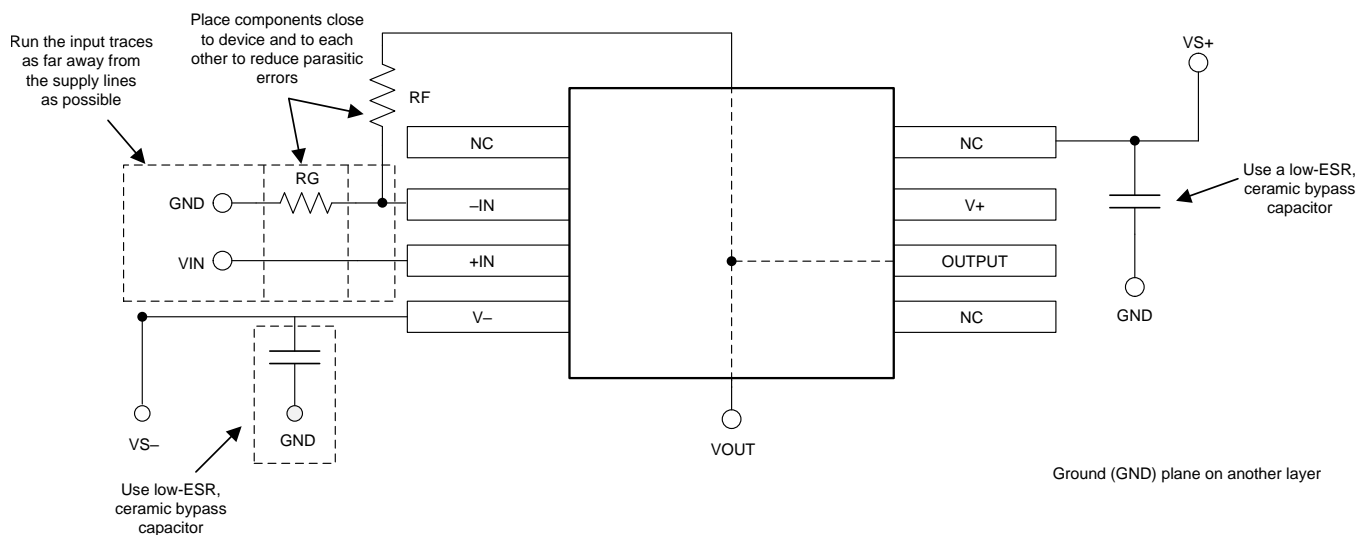
请参阅如下相关文档:

- 德州仪器 (TI), 《[ADS8326 16 位高速 2.7V 至 5.5V 低功耗采样模数转换器](#)》
- 德州仪器 (TI), 《[电路板布局技巧](#)》
- 德州仪器 (TI), 《[用直观方式补偿跨阻放大器](#)》
- 德州仪器 (TI), 《[FilterPro™ 用户指南](#)》
- 德州仪器 (TI), 《[FET 跨阻放大器噪声分析](#)》
- 德州仪器 (TI), 《[高速运算放大器噪声分析](#)》
- 德州仪器 (TI), 《[OPA380 和 OPA2380 精密高速跨阻放大器](#)》
- 德州仪器 (TI), 《[OPA354、OPA2354 和 OPA4354 250MHz 轨至轨 I/O CMOS 运算放大器](#)》
- 德州仪器 (TI), 《[具有关断功能的 OPA355、OPA2355 和 OPA3355 200MHz CMOS 运算放大器](#)》
- 德州仪器 (TI), 《[OPA656 宽带单位增益稳定 FET 输入运算放大器](#)》
- 德州仪器 (TI), 《[功率放大器应力和功率处理限制](#)》

### 11.2 相关链接

下表列出了快速访问链接。类别包括技术文档、支持与社区资源、工具和软件，以及申请样片或购买产品的快速链接。

表 2. 相关链接

器件	产品文件夹	立即订购	技术文档	工具与软件	支持和社区
OPA354A-Q1	<a href="#">单击此处</a>	<a href="#">单击此处</a>	<a href="#">单击此处</a>	<a href="#">单击此处</a>	<a href="#">单击此处</a>
OPA2354A-Q1	<a href="#">单击此处</a>	<a href="#">单击此处</a>	<a href="#">单击此处</a>	<a href="#">单击此处</a>	<a href="#">单击此处</a>
OPA4354-Q1	<a href="#">单击此处</a>	<a href="#">单击此处</a>	<a href="#">单击此处</a>	<a href="#">单击此处</a>	<a href="#">单击此处</a>

### 11.3 接收文档更新通知

要接收文档更新通知，请导航至 [TI.com.cn](#) 上的器件产品文件夹。单击右上角的 [通知我](#) 进行注册，即可每周接收产品信息更改摘要。有关更改的详细信息，请查看任何已修订文档中包含的修订历史记录。

### 11.4 社区资源

下列链接提供到 TI 社区资源的连接。链接的内容由各个分销商“按照原样”提供。这些内容并不构成 TI 技术规范，并且不一定反映 TI 的观点；请参阅 TI 的 [《使用条款》](#)。

**TI E2E™ 在线社区** [TI 的工程师对工程师 \(E2E\) 社区](#)。此社区的创建目的在于促进工程师之间的协作。在 [e2e.ti.com](#) 中，您可以咨询问题、分享知识、拓展思路并与同行工程师一道帮助解决问题。

**设计支持** [TI 参考设计支持](#) 可帮助您快速查找有帮助的 E2E 论坛、设计支持工具以及技术支持的联系信息。

### 11.5 商标

E2E is a trademark of Texas Instruments.

FilterPro is a trademark of Texas Instruments Incorporated.

All other trademarks are the property of their respective owners.

### 11.6 静电放电警告



这些装置包含有限的内置 ESD 保护。存储或装卸时，应将导线一起截短或将装置放置于导电泡棉中，以防止 MOS 门极遭受静电损伤。

## 11.7 术语表

[SLYZ022](#) — *TI* 术语表。

这份术语表列出并解释术语、缩写和定义。

## 12 机械、封装和可订购信息

以下页面包含机械、封装和可订购信息。这些信息是指定器件的最新可用数据。数据如有变更，恕不另行通知，且不会对此文档进行修订。如需获取此产品说明书的浏览器版本，请查阅左侧的导航栏。

## 重要声明和免责声明

TI 均以“原样”提供技术性数据（包括数据表）、设计资源（包括参考设计）、应用或其他设计建议、网络工具、安全信息和其他资源，不保证其中不含任何瑕疵，且不做任何明示或暗示的担保，包括但不限于对适销性、适合某特定用途或不侵犯任何第三方知识产权的暗示担保。

所述资源可供专业开发人员应用TI 产品进行设计使用。您将对以下行为独自承担全部责任：(1) 针对您的应用选择合适的TI 产品；(2) 设计、验证并测试您的应用；(3) 确保您的应用满足相应标准以及任何其他安全、安保或其他要求。所述资源如有变更，恕不另行通知。TI 对您使用所述资源的授权仅限于开发资源所涉及TI 产品的相关应用。除此之外不得复制或展示所述资源，也不提供其它TI 或任何第三方的知识产权授权许可。如因使用所述资源而产生任何索赔、赔偿、成本、损失及债务等，TI 对此概不负责，并且您须赔偿由此对TI 及其代表造成的损害。

TI 所提供产品均受TI 的销售条款 (<http://www.ti.com.cn/zh-cn/legal/termsofsale.html>) 以及ti.com.cn上或随附TI产品提供的其他可适用条款的约束。TI提供所述资源并不扩展或以其他方式更改TI 针对TI 产品所发布的可适用的担保范围或担保免责声明。

邮寄地址：上海市浦东新区世纪大道 1568 号中建大厦 32 楼，邮政编码：200122  
Copyright © 2018 德州仪器半导体技术（上海）有限公司

**PACKAGING INFORMATION**

Orderable Device	Status (1)	Package Type	Package Drawing	Pins	Package Qty	Eco Plan (2)	Lead finish/ Ball material (6)	MSL Peak Temp (3)	Op Temp (°C)	Device Marking (4/5)	Samples
OPA2354AQDGKRQ1	ACTIVE	VSSOP	DGK	8	2500	RoHS & Green	NIPDAU   NIPDAUAG	Level-2-260C-1 YEAR	-40 to 125	OSLQ	<a href="#">Samples</a>
OPA354AQDBVRQ1	ACTIVE	SOT-23	DBV	5	3000	RoHS & Green	NIPDAU	Level-2-260C-1 YEAR	-40 to 125	OSFQ	<a href="#">Samples</a>
OPA4354AQPWRQ1	ACTIVE	TSSOP	PW	14	2000	RoHS & Green	NIPDAU	Level-3-260C-168 HR	-40 to 125	4354Q1	<a href="#">Samples</a>

(1) The marketing status values are defined as follows:

**ACTIVE:** Product device recommended for new designs.

**LIFEBUY:** TI has announced that the device will be discontinued, and a lifetime-buy period is in effect.

**NRND:** Not recommended for new designs. Device is in production to support existing customers, but TI does not recommend using this part in a new design.

**PREVIEW:** Device has been announced but is not in production. Samples may or may not be available.

**OBSELETE:** TI has discontinued the production of the device.

(2) **RoHS:** TI defines "RoHS" to mean semiconductor products that are compliant with the current EU RoHS requirements for all 10 RoHS substances, including the requirement that RoHS substance do not exceed 0.1% by weight in homogeneous materials. Where designed to be soldered at high temperatures, "RoHS" products are suitable for use in specified lead-free processes. TI may reference these types of products as "Pb-Free".

**RoHS Exempt:** TI defines "RoHS Exempt" to mean products that contain lead but are compliant with EU RoHS pursuant to a specific EU RoHS exemption.

**Green:** TI defines "Green" to mean the content of Chlorine (Cl) and Bromine (Br) based flame retardants meet JS709B low halogen requirements of <=1000ppm threshold. Antimony trioxide based flame retardants must also meet the <=1000ppm threshold requirement.

(3) MSL, Peak Temp. - The Moisture Sensitivity Level rating according to the JEDEC industry standard classifications, and peak solder temperature.

(4) There may be additional marking, which relates to the logo, the lot trace code information, or the environmental category on the device.

(5) Multiple Device Markings will be inside parentheses. Only one Device Marking contained in parentheses and separated by a "~" will appear on a device. If a line is indented then it is a continuation of the previous line and the two combined represent the entire Device Marking for that device.

(6) Lead finish/Ball material - Orderable Devices may have multiple material finish options. Finish options are separated by a vertical ruled line. Lead finish/Ball material values may wrap to two lines if the finish value exceeds the maximum column width.

**Important Information and Disclaimer:**The information provided on this page represents TI's knowledge and belief as of the date that it is provided. TI bases its knowledge and belief on information provided by third parties, and makes no representation or warranty as to the accuracy of such information. Efforts are underway to better integrate information from third parties. TI has taken and continues to take reasonable steps to provide representative and accurate information but may not have conducted destructive testing or chemical analysis on incoming materials and chemicals. TI and TI suppliers consider certain information to be proprietary, and thus CAS numbers and other limited information may not be available for release.

In no event shall TI's liability arising out of such information exceed the total purchase price of the TI part(s) at issue in this document sold by TI to Customer on an annual basis.

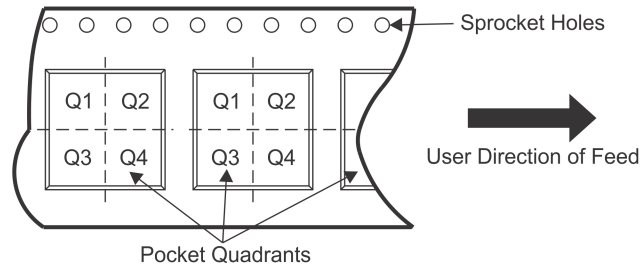

**TAPE AND REEL INFORMATION**

**QUADRANT ASSIGNMENTS FOR PIN 1 ORIENTATION IN TAPE**

\*All dimensions are nominal

Device	Package Type	Package Drawing	Pins	SPQ	Reel Diameter (mm)	Reel Width W1 (mm)	A0 (mm)	B0 (mm)	K0 (mm)	P1 (mm)	W (mm)	Pin1 Quadrant
OPA354AQDBVRQ1	SOT-23	DBV	5	3000	179.0	8.4	3.2	3.2	1.4	4.0	8.0	Q3
OPA4354AQPWRQ1	TSSOP	PW	14	2000	330.0	12.4	6.9	5.6	1.6	8.0	12.0	Q1

## TAPE AND REEL BOX DIMENSIONS



\*All dimensions are nominal

Device	Package Type	Package Drawing	Pins	SPQ	Length (mm)	Width (mm)	Height (mm)
OPA354AQDBVRQ1	SOT-23	DBV	5	3000	213.0	191.0	35.0
OPA4354AQPWRQ1	TSSOP	PW	14	2000	853.0	449.0	35.0



**DBV0005A**

**PACKAGE OUTLINE**

**SOT-23 - 1.45 mm max height**

SMALL OUTLINE TRANSISTOR

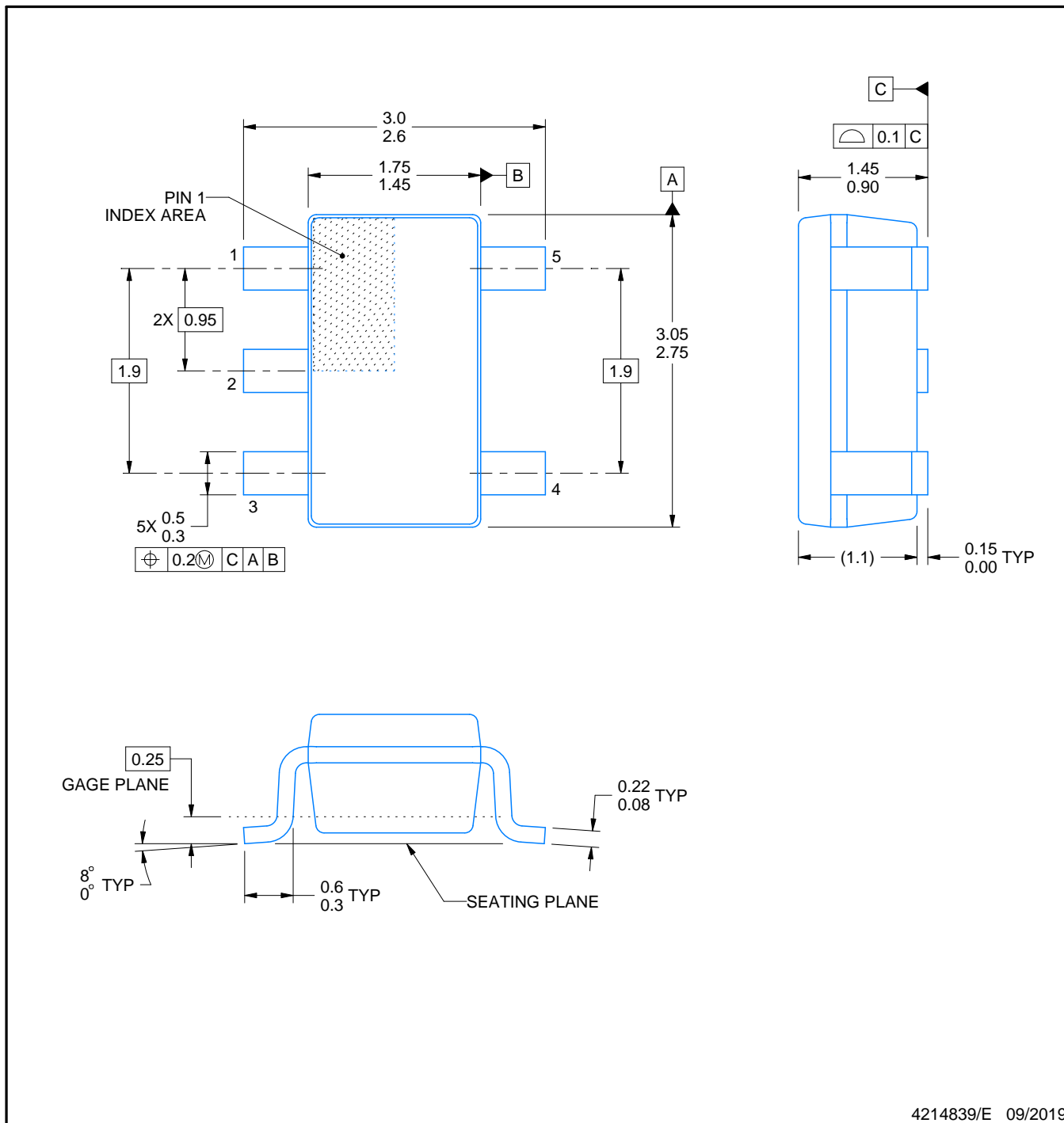

4214839/E 09/2019

**NOTES:**

1. All linear dimensions are in millimeters. Any dimensions in parenthesis are for reference only. Dimensioning and tolerancing per ASME Y14.5M.
2. This drawing is subject to change without notice.
3. Reference JEDEC MO-178.
4. Body dimensions do not include mold flash, protrusions, or gate burrs. Mold flash, protrusions, or gate burrs shall not exceed 0.15 mm per side.

# EXAMPLE BOARD LAYOUT

DBV0005A

SOT-23 - 1.45 mm max height

SMALL OUTLINE TRANSISTOR



LAND PATTERN EXAMPLE  
EXPOSED METAL SHOWN  
SCALE:15X

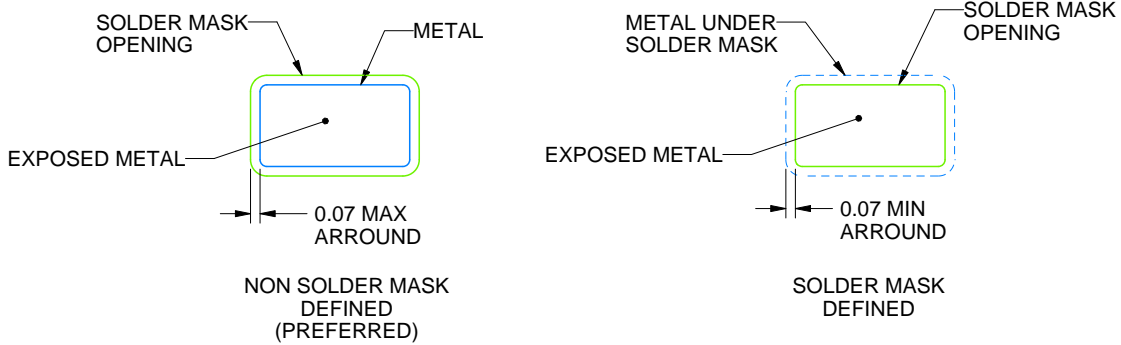

SOLDER MASK DETAILS

4214839/E 09/2019

NOTES: (continued)

- 5. Publication IPC-7351 may have alternate designs.
- 6. Solder mask tolerances between and around signal pads can vary based on board fabrication site.

# EXAMPLE STENCIL DESIGN

DBV0005A

SOT-23 - 1.45 mm max height

SMALL OUTLINE TRANSISTOR



SOLDER PASTE EXAMPLE  
BASED ON 0.125 mm THICK STENCIL  
SCALE:15X

4214839/E 09/2019

NOTES: (continued)

7. Laser cutting apertures with trapezoidal walls and rounded corners may offer better paste release. IPC-7525 may have alternate design recommendations.
8. Board assembly site may have different recommendations for stencil design.

PW (R-PDSO-G14)

PLASTIC SMALL OUTLINE



- NOTES:
- A. All linear dimensions are in millimeters. Dimensioning and tolerancing per ASME Y14.5M-1994.
  - B. This drawing is subject to change without notice.
  - C. Body length does not include mold flash, protrusions, or gate burrs. Mold flash, protrusions, or gate burrs shall not exceed 0,15 each side.
  - D. Body width does not include interlead flash. Interlead flash shall not exceed 0,25 each side.
  - E. Falls within JEDEC MO-153

PW (R-PDSO-G14)

PLASTIC SMALL OUTLINE



4211284-2/G 08/15

- NOTES:
- All linear dimensions are in millimeters.
  - This drawing is subject to change without notice.
  - Publication IPC-7351 is recommended for alternate designs.
  - Laser cutting apertures with trapezoidal walls and also rounding corners will offer better paste release. Customers should contact their board assembly site for stencil design recommendations. Refer to IPC-7525 for other stencil recommendations.
  - Customers should contact their board fabrication site for solder mask tolerances between and around signal pads.

DGK (S-PDSO-G8)

PLASTIC SMALL-OUTLINE PACKAGE

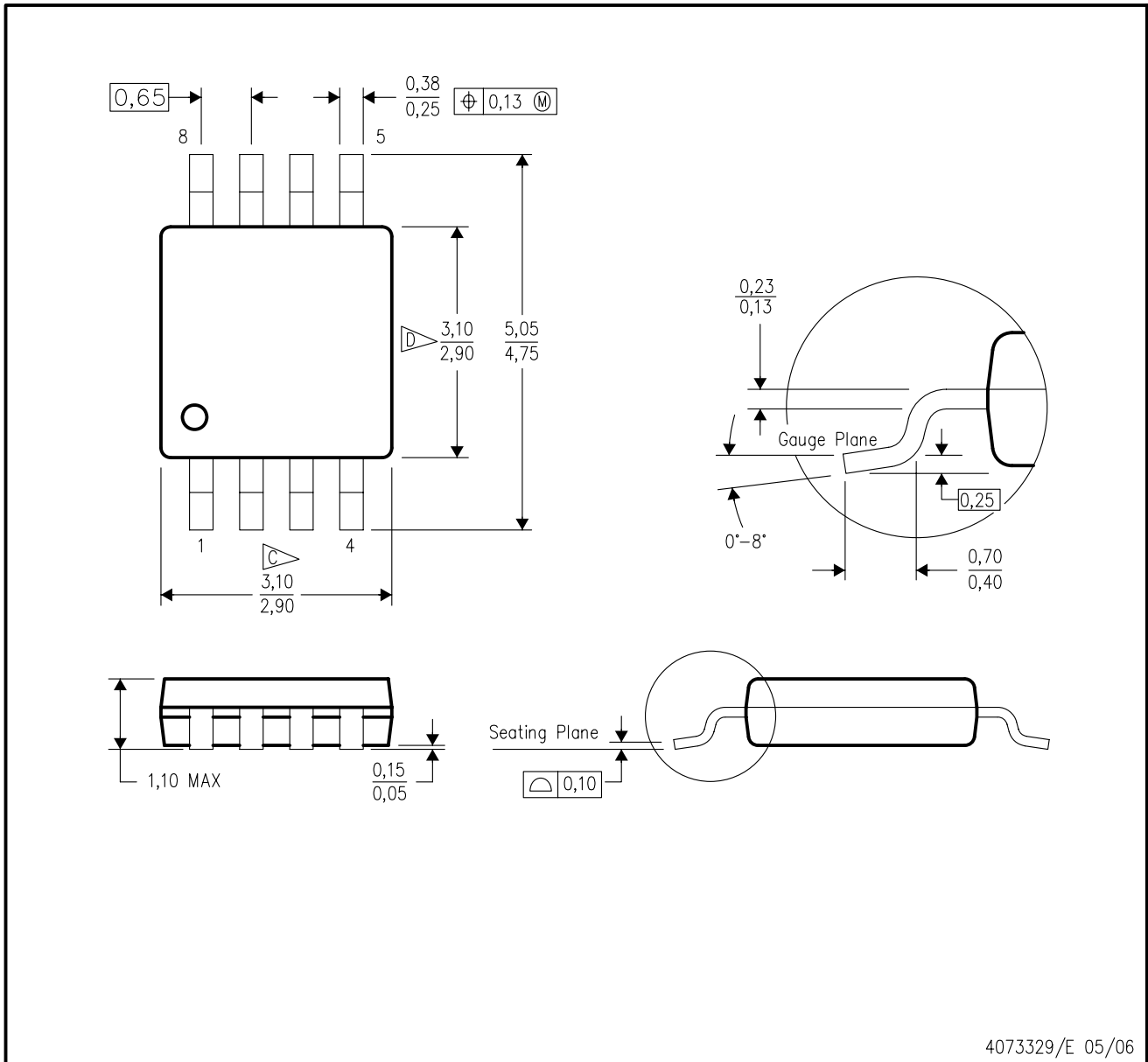

- NOTES:
- A. All linear dimensions are in millimeters.
  - B. This drawing is subject to change without notice.
  - $\nabla$  C Body length does not include mold flash, protrusions, or gate burrs. Mold flash, protrusions, or gate burrs shall not exceed 0.15 per end.
  - $\nabla$  D Body width does not include interlead flash. Interlead flash shall not exceed 0.50 per side.
  - E. Falls within JEDEC MO-187 variation AA, except interlead flash.





- NOTES:
- A. All linear dimensions are in millimeters.
  - B. This drawing is subject to change without notice.
  - C. Publication IPC-7351 is recommended for alternate designs.
  - D. Laser cutting apertures with trapezoidal walls and also rounding corners will offer better paste release. Customers should contact their board assembly site for stencil design recommendations. Refer to IPC-7525 for other stencil recommendations.
  - E. Customers should contact their board fabrication site for solder mask tolerances between and around signal pads.

## 重要声明和免责声明

TI 提供技术和可靠性数据 (包括数据表)、设计资源 (包括参考设计)、应用或其他设计建议、网络工具、安全信息和其他资源, 不保证没有瑕疵且不做任何明示或暗示的担保, 包括但不限于对适销性、某特定用途方面的适用性或不侵犯任何第三方知识产权的暗示担保。

这些资源可供使用 TI 产品进行设计的熟练开发人员使用。您将自行承担以下全部责任: (1) 针对您的应用选择合适的 TI 产品, (2) 设计、验证并测试您的应用, (3) 确保您的应用满足相应标准以及任何其他安全、安保或其他要求。这些资源如有变更, 恕不另行通知。TI 授权您仅可将这些资源用于研发本资源所述的 TI 产品的应用。严禁对这些资源进行其他复制或展示。您无权使用任何其他 TI 知识产权或任何第三方知识产权。您应全额赔偿因在这些资源的使用中对 TI 及其代表造成的任何索赔、损害、成本、损失和债务, TI 对此概不负责。

TI 提供的产品受 TI 的销售条款 (<https://www.ti.com.cn/zh-cn/legal/termsofsale.html>) 或 [ti.com.cn](https://www.ti.com.cn) 上其他适用条款/TI 产品随附的其他适用条款的约束。TI 提供这些资源并不会扩展或以其他方式更改 TI 针对 TI 产品发布的适用的担保或担保免责声明。

邮寄地址: 上海市浦东新区世纪大道 1568 号中建大厦 32 楼, 邮政编码: 200122  
Copyright © 2021 德州仪器半导体技术 (上海) 有限公司