

## LM3224 615kHz/1.25MHz Step-up PWM DC/DC Converter

Check for Samples: [LM3224](#)

### FEATURES

- Operating Voltage Range of 2.7V to 7V
- 615kHz/1.25MHz Pin Selectable Frequency Operation
- Over Temperature Protection
- Optional Soft-Start Function
- 8-Lead VSSOP Package

### APPLICATIONS

- TFT Bias Supplies
- Handheld Devices
- Portable Applications
- GSM/CDMA Phones
- Digital Cameras
- White LED Flash/Torch Applications

### DESCRIPTION

The LM3224 is a step-up DC/DC converter with a  $0.15\Omega$  (typ.), 2.45A (typ.) internal switch and pin selectable operating frequency. With the ability to convert 3.3V to multiple outputs of 8V, -8V, and 23V, the LM3224 is an ideal part for biasing TFT displays. With the high current switch it is also ideal for driving high current white LEDs for flash applications. The LM3224 can be operated at switching frequencies of 615kHz and 1.25MHz allowing for easy filtering and low noise. An external compensation pin gives the user flexibility in setting frequency compensation, which makes possible the use of small, low ESR ceramic capacitors at the output. An external soft-start pin allows the user to control the amount of inrush current during start up. The LM3224 is available in a low profile 8-lead VSSOP package.

### Typical Application Circuit

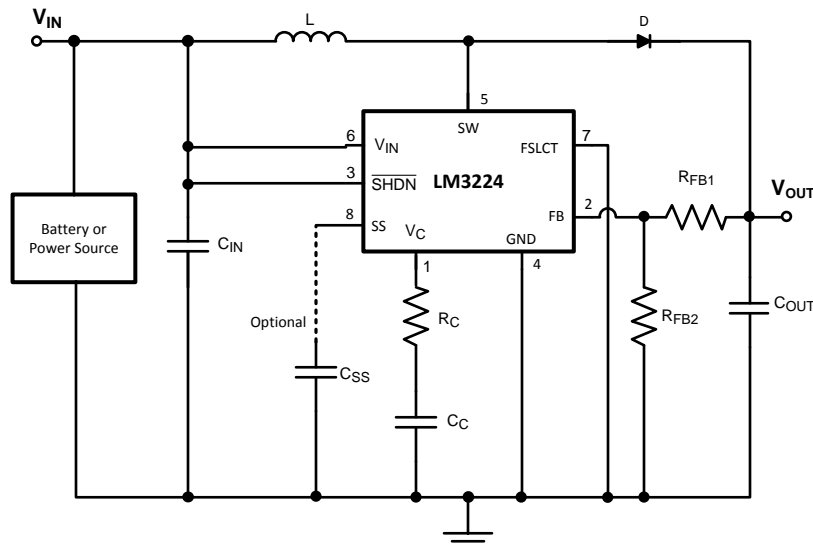

Please be aware that an important notice concerning availability, standard warranty, and use in critical applications of Texas Instruments semiconductor products and disclaimers thereto appears at the end of this data sheet.

All trademarks are the property of their respective owners.

## Connection Diagram

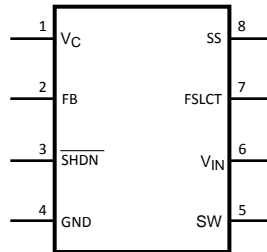

**Figure 1. 8-Lead Plastic VSSOP  
Top View  
Package Number DGK0008A**

### PIN DESCRIPTIONS

Pin	Name	Function
1	$V_C$	Compensation network connection. Connected to the output of the voltage error amplifier.
2	FB	Output voltage feedback input.
3	$\overline{\text{SHDN}}$	Shutdown control input, active low. This pin has an internal pulldown resistor so the default condition is off. The pin must be pulled high to turn on the device.
4	GND	Analog and power ground.
5	SW	Power switch input. Switch connected between SW pin and GND pin.
6	$V_{IN}$	Analog power input.
7	FSLCT	Switching frequency select input. $V_{IN} = 1.25\text{MHz}$ . Ground = 615kHz.
8	SS	Soft-start Pin.



### Absolute Maximum Ratings<sup>(1) (2)(2)</sup>

V <sub>IN</sub>		7.5V
SW Voltage		21V
FB Voltage <sup>(3)</sup>		7V
V <sub>C</sub> Voltage <sup>(4)</sup>		1.26V ± 0.3V
$\overline{\text{SHDN}}$ Voltage		7.5V
FSLCT		7.5V
Maximum Junction Temperature		150°C
Power Dissipation <sup>(5)</sup>		Internally Limited
Lead Temperature		300°C
Vapor Phase (60 sec.)		215°C
Infrared (15 sec.)		220°C
ESD Susceptibility <sup>(6)</sup>	Human Body Model	2kV
	Machine Model	200V

- (1) If Military/Aerospace specified devices are required, please contact the Texas Instruments Sales Office/ Distributors for availability and specifications
- (2) Absolute maximum ratings are limits beyond which damage to the device may occur. Operating Ratings are conditions for which the device is intended to be functional, but device parameter specifications may not be ensured. For ensured specifications and test conditions, see the [Electrical Characteristics](#)<sup>0</sup>.
- (3) The FB pin should never exceed V<sub>IN</sub>.
- (4) Under normal operation the V<sub>C</sub> pin may go to voltages above this value. This maximum rating is for the possibility of a voltage being applied to the pin, however the V<sub>C</sub> pin should never have a voltage directly applied to it.
- (5) The maximum allowable power dissipation is a function of the maximum junction temperature, T<sub>J</sub>(MAX), the junction-to-ambient thermal resistance,  $\theta_{JA}$ , and the ambient temperature, T<sub>A</sub>. The maximum allowable power dissipation at any ambient temperature is calculated using:  $P_D(\text{MAX}) = (T_{J(\text{MAX})} - T_A) / \theta_{JA}$ . Exceeding the maximum allowable power dissipation will cause excessive die temperature, and the regulator will go into thermal shutdown.
- (6) The human body model is a 100 pF capacitor discharged through a 1.5k $\Omega$  resistor into each pin. The machine model is a 200pF capacitor discharged directly into each pin.

### Operating Conditions

Operating Junction Temperature Range	-40°C to +125°C
Storage Temperature	-65°C to +150°C
Supply Voltage	2.7V to 7V
Maximum Output Voltage	20V

**Electrical Characteristics<sup>(1)</sup>**

Specifications in standard type face are for  $T_J = 25^\circ\text{C}$  and those with **boldface type** apply over the full **Operating Temperature Range** ( $T_J = -40^\circ\text{C}$  to  $+125^\circ\text{C}$ ).  $V_{IN} = 2.7\text{V}$ ,  $FSLCT = SHDN = V_{IN}$ , and  $I_L = 0\text{A}$ , unless otherwise specified.

Symbol	Parameter	Conditions	Min (1)	Typ (2)	Max (1)	Units
$I_Q$	Quiescent Current	FB = 2V (Not Switching)		1.3	<b>2.0</b>	mA
		$V_{SHDN} = 0\text{V}$		0.1	<b>2.0</b>	$\mu\text{A}$
$V_{FB}$	Feedback Voltage		<b>1.2285</b>	1.26	<b>1.2915</b>	V
$I_{CL}^{(3)}$	Switch Current Limit	$V_{IN} = 2.7\text{V}^{(4)}$	1.9	2.45	2.8	A
		$V_{IN} = 3\text{V}$ , $V_{OUT} = 8\text{V}$		2.1		
		$V_{IN} = 3\text{V}$ , $V_{OUT} = 5\text{V}$		2.2		
$\%V_{FB}/\Delta V_{IN}$	Feedback Voltage Line Regulation	$2.7\text{V} \leq V_{IN} \leq 7\text{V}$		0.085	0.15	$\%/V$
$I_B$	FB Pin Bias Current <sup>(5)(6)</sup>			35	<b>250</b>	nA
$I_{SS}$	SS Pin Current		<b>7.5</b>	11	<b>13</b>	$\mu\text{A}$
$V_{SS}$	SS Pin Voltage		<b>1.2090</b>	1.2430	<b>1.2622</b>	
$V_{IN}$	Input Voltage Range		<b>2.7</b>		<b>7</b>	V
$g_m$	Error Amp Transconductance	$\Delta I = 5\mu\text{A}$	40	87	135	$\mu\text{mho}$
$A_V$	Error Amp Voltage Gain			78		V/V
$D_{MAX}$	Maximum Duty Cycle		<b>85</b>	92.5		%
$f_S$	Switching Frequency	FSLCT = Ground	<b>450</b>	615	<b>750</b>	kHz
		FSLCT = $V_{IN}$	<b>0.9</b>	1.25	<b>1.5</b>	MHz
$I_{SHDN}$	Shutdown Pin Current	$V_{SHDN} = 2.7\text{V}$		2.4	<b>5.0</b>	$\mu\text{A}$
		$V_{SHDN} = 0.3\text{V}$		0.3	<b>1.2</b>	
$I_L$	Switch Leakage Current	$V_{SW} = 20\text{V}$		0.2	<b>8.0</b>	$\mu\text{A}$
$R_{DS(ON)}$	Switch $R_{DS(ON)}$	$V_{IN} = 2.7\text{V}$ , $I_{SW} = 1\text{A}$		0.15	<b>0.4</b>	$\Omega$
$T_{HSHDN}$	Shutdown Threshold	Output High	<b>1.2</b>	0.8		V
		Output Low		0.8	<b>0.3</b>	V
UVP	On Threshold		<b>2.3</b>	2.5		V
	Off Threshold			2.6	<b>2.7</b>	V

- (1) All limits ensured at room temperature (standard typeface) and at temperature extremes (bold typeface). All room temperature limits are 100% production tested. All limits at temperature extremes are ensured via correlation using standard Statistical Quality Control (SQC) methods. All limits are used to calculate Average Outgoing Quality Level (AOQL).
- (2) Typical numbers are at  $25^\circ\text{C}$  and represent the most likely norm.
- (3) Duty cycle affects current limit due to ramp generator.
- (4) Current limit at 0% duty cycle. See [Typical Performance Characteristics](#) for Switch Current Limit vs.  $V_{IN}$ .
- (5) Bias current flows into FB pin.
- (6) The FB pin should never exceed  $V_{IN}$ .

Typical Performance Characteristics

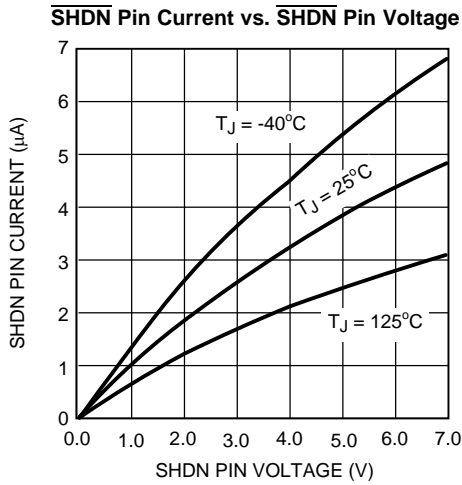

Figure 2.

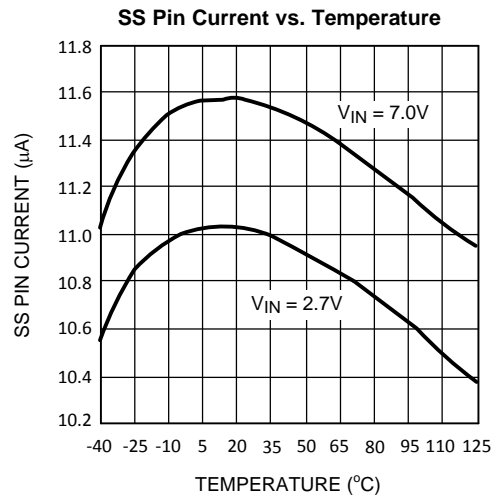

Figure 3.

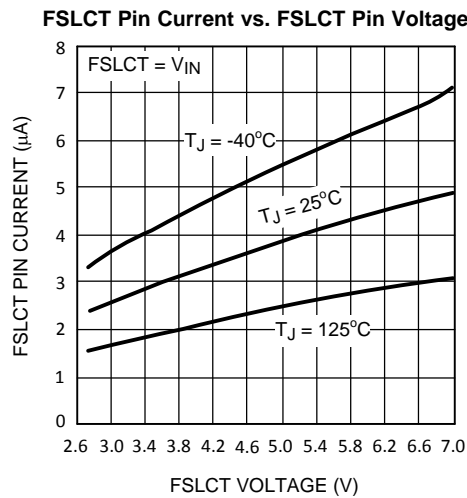

Figure 4.

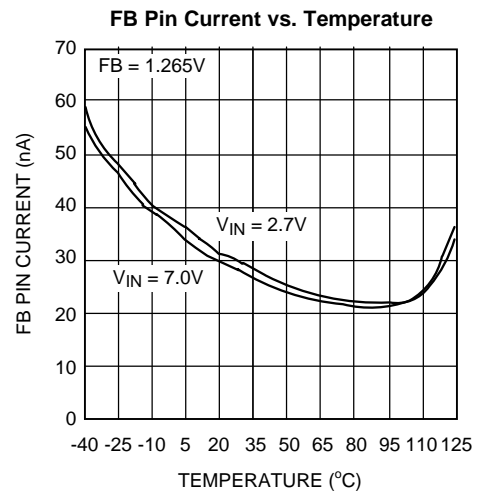

Figure 5.

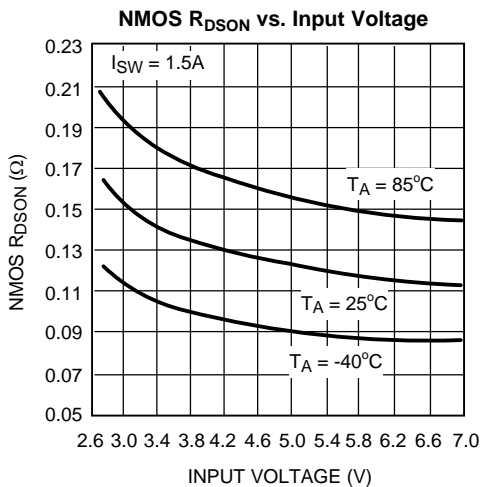

Figure 6.

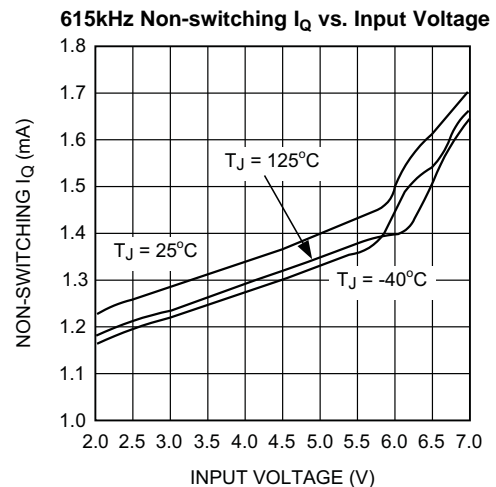

Figure 7.

**Typical Performance Characteristics (continued)**

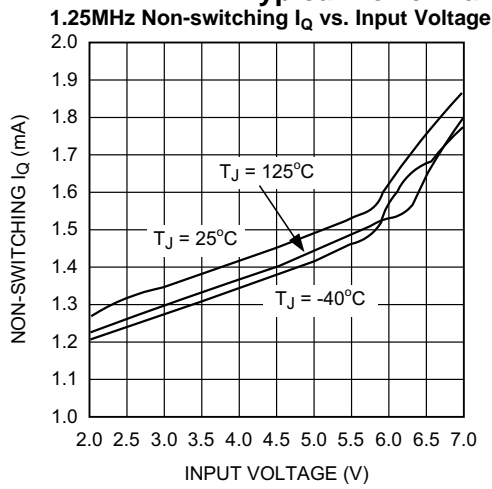

Figure 8.

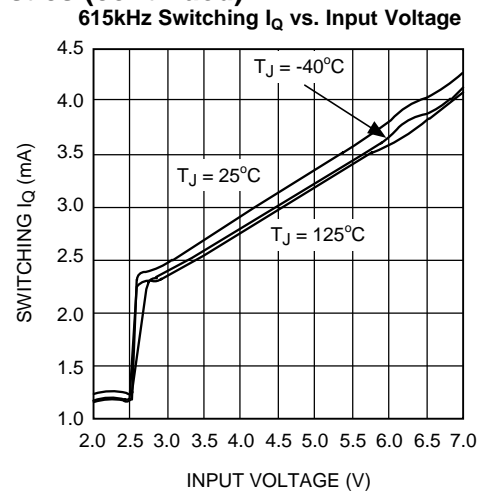

Figure 9.

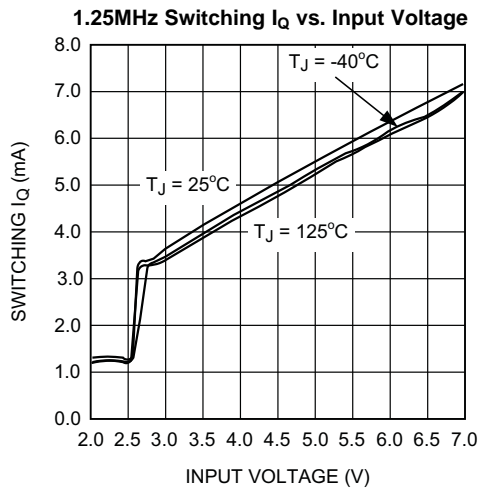

Figure 10.

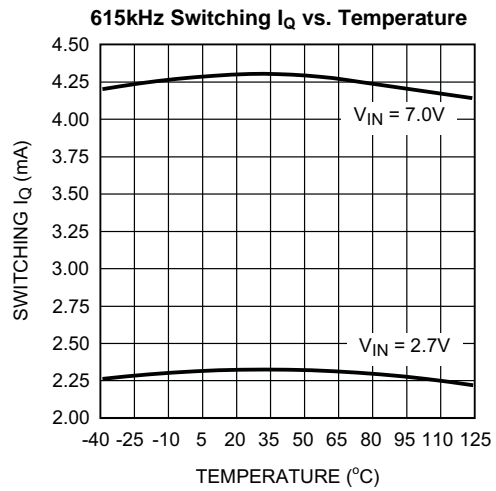

Figure 11.

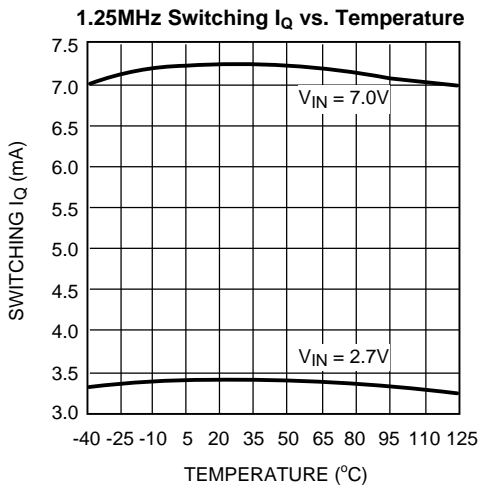

Figure 12.

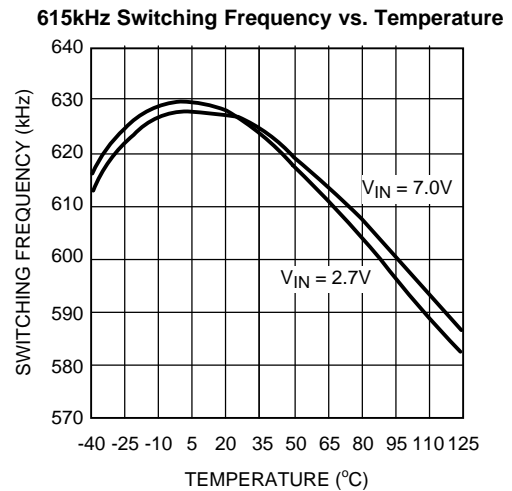

Figure 13.

**Typical Performance Characteristics (continued)**

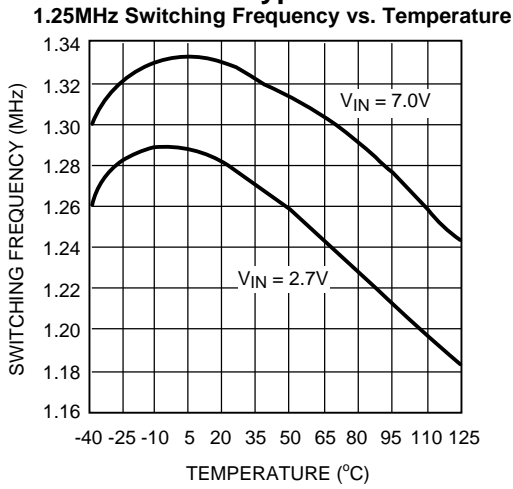

Figure 14.

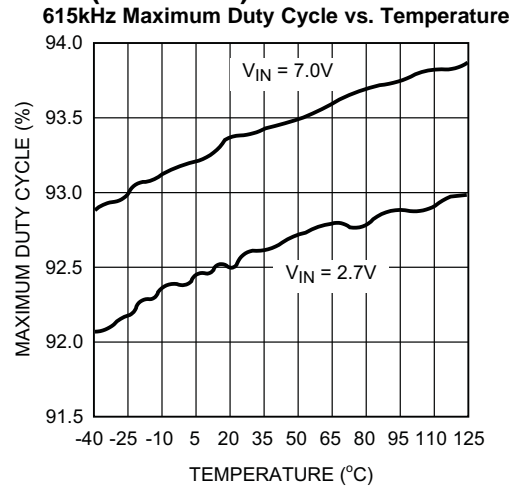

Figure 15.

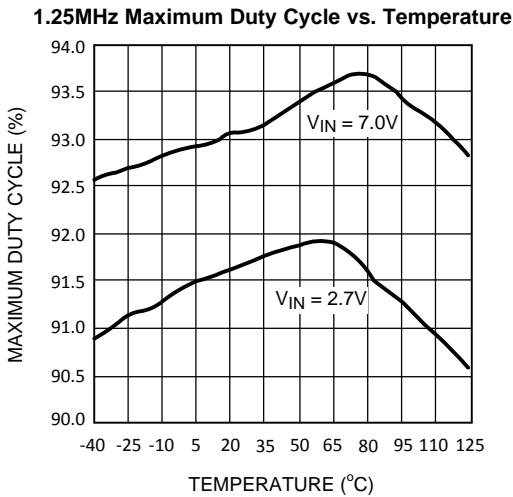

Figure 16.

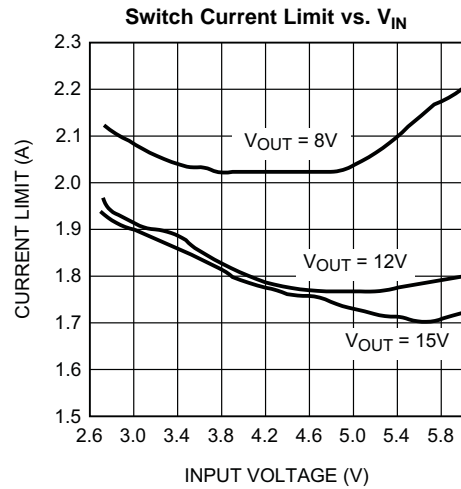

Figure 17.

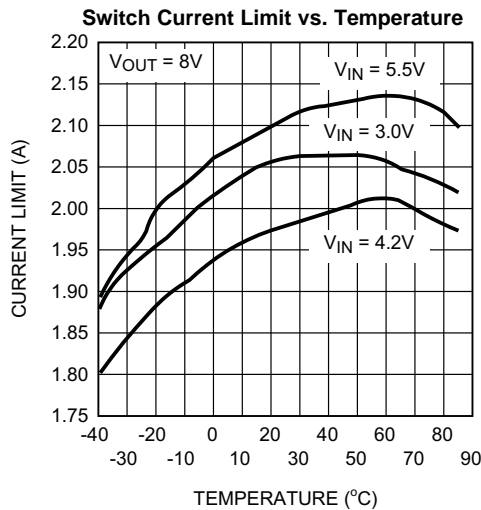

Figure 18.

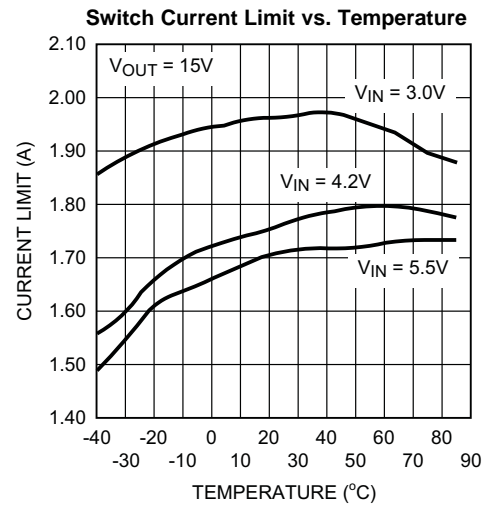
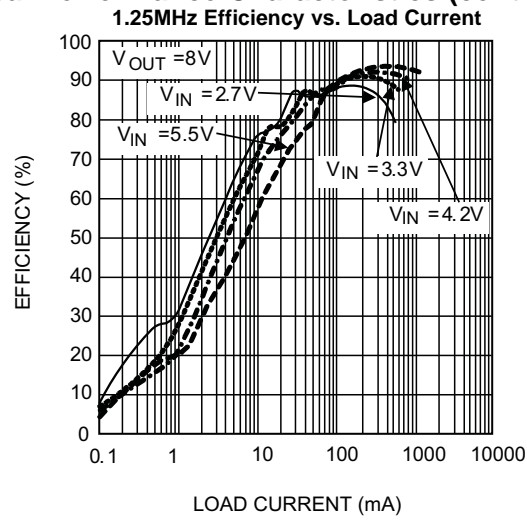

Figure 19.



Typical Performance Characteristics (continued)



## OPERATION

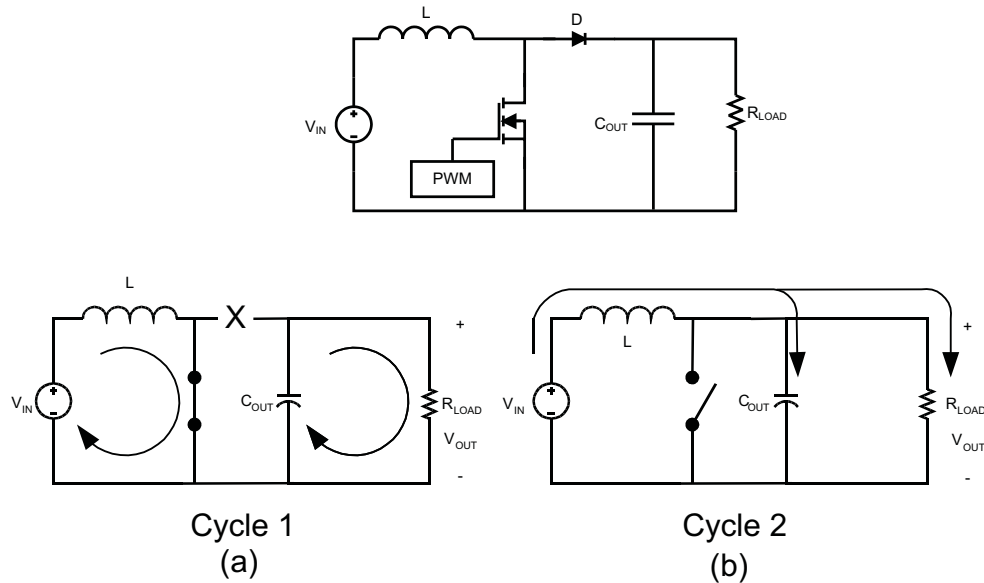

**Figure 21. Simplified Boost Converter Diagram**  
**(a) First Cycle of Operation (b) Second Cycle Of Operation**

## CONTINUOUS CONDUCTION MODE

The LM3224 is a current-mode, PWM boost regulator. A boost regulator steps the input voltage up to a higher output voltage. In continuous conduction mode (when the inductor current never reaches zero at steady state), the boost regulator operates in two cycles.

In the first cycle of operation, shown in [Figure 21 \(a\)](#), the transistor is closed and the diode is reverse biased. Energy is collected in the inductor and the load current is supplied by  $C_{OUT}$ .

The second cycle is shown in [Figure 21 \(b\)](#). During this cycle, the transistor is open and the diode is forward biased. The energy stored in the inductor is transferred to the load and output capacitor.

The ratio of these two cycles determines the output voltage. The output voltage is defined approximately as:

$$V_{OUT} = \frac{V_{IN}}{1-D}, D' = (1-D) = \frac{V_{IN}}{V_{OUT}}$$

where

- D is the duty cycle of the switch (1)

D and D' will be required for design calculations.

## SETTING THE OUTPUT VOLTAGE

The output voltage is set using the feedback pin and a resistor divider connected to the output as shown in the typical operating circuit. The feedback pin voltage is 1.26V, so the ratio of the feedback resistors sets the output voltage according to the following equation:

$$R_{FB1} = R_{FB2} \times \frac{V_{OUT} - 1.26}{1.26} \Omega \quad (2)$$

## SOFT-START CAPACITOR

The LM3224 has a soft-start pin that can be used to limit the inductor inrush current on start-up. The external SS pin is used to tailor the soft-start for a specific application but is not required for all applications and can be left open when not needed. When used, a current source charges the external soft-start capacitor,  $C_{SS}$ . The soft-start time can be estimated as:

$$T_{SS} = C_{SS} \cdot 1.24V / I_{SS} \quad (3)$$

## THERMAL SHUTDOWN

The LM3224 includes thermal shutdown protection. If the die temperature exceeds 140°C the regulator will shut off the power switch, significantly reducing power dissipation in the device. The switch will remain off until the die temperature is reduced to approximately 120°C. If the cause of the excess heating is not removed (excessive ambient temperature, excessive power dissipation, or both) the device will continue to cycle on and off in this manner to protect from damage.

## INTRODUCTION TO COMPENSATION

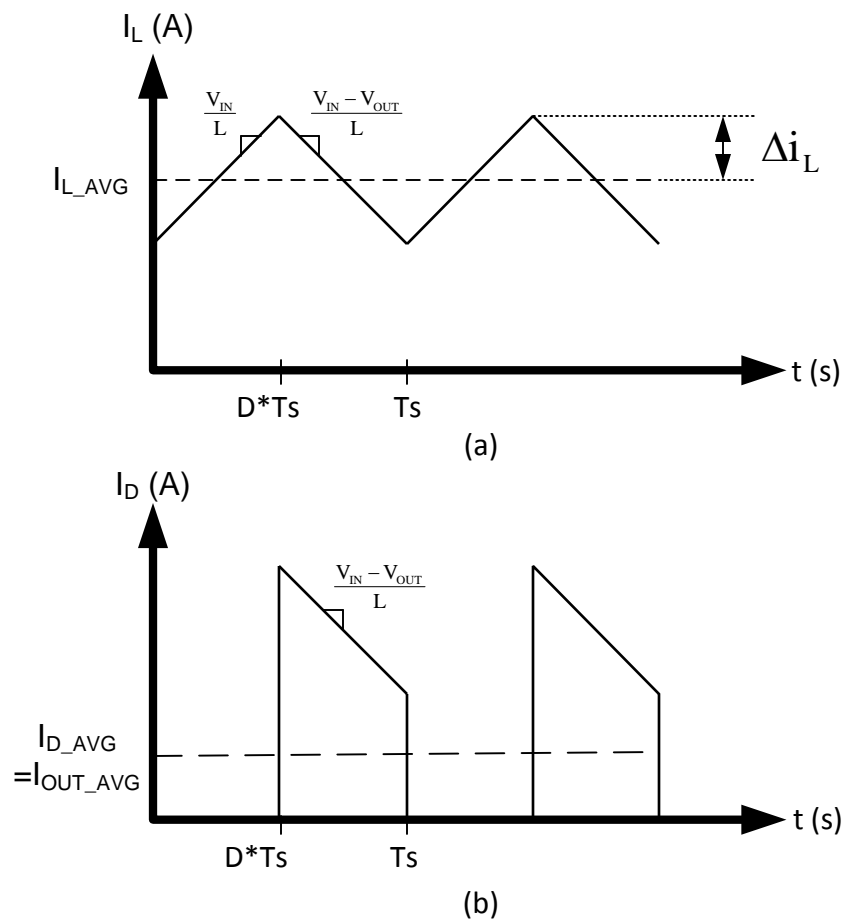

Figure 22. (a) Inductor current. (b) Diode current.

The LM3224 is a current mode PWM boost converter. The signal flow of this control scheme has two feedback loops, one that senses switch current and one that senses output voltage.

To keep a current programmed control converter stable above duty cycles of 50%, the inductor must meet certain criteria. The inductor, along with input and output voltage, will determine the slope of the current through the inductor (see [Figure 22 \(a\)](#)). If the slope of the inductor current is too great, the circuit will be unstable above duty cycles of 50%. A 10µH to 15µH inductor is recommended for most 615 kHz applications, while a 4.7µH to 10µH inductor may be used for most 1.25 MHz applications. If the duty cycle is approaching the maximum of 85%, it may be necessary to increase the inductance by as much as 2X. See *Inductor and Diode Selection* for more detailed inductor sizing.

The LM3224 provides a compensation pin ( $V_C$ ) to customize the voltage loop feedback. It is recommended that a series combination of  $R_C$  and  $C_C$  be used for the compensation network, as shown in the typical application circuit. For any given application, there exists a unique combination of  $R_C$  and  $C_C$  that will optimize the performance of the LM3224 circuit in terms of its transient response. The series combination of  $R_C$  and  $C_C$  introduces a pole-zero pair according to the following equations:

$$f_{zC} = \frac{1}{2\pi R_C C_C} \text{ Hz} \quad (4)$$

$$f_{pC} = \frac{1}{2\pi(R_C + R_O)C_C} \text{ Hz}$$

where

- $R_O$  is the output impedance of the error amplifier (approximately 900kΩ) (5)

For most applications, performance can be optimized by choosing values within the range  $5\text{k}\Omega \leq R_C \leq 100\text{k}\Omega$  ( $R_C$  can be up to 200kΩ if  $C_{C2}$  is used, see *High Output Capacitor ESR Compensation*) and  $680\text{pF} \leq C_C \leq 10\text{nF}$ . Refer to the *Applications Information* section for recommended values for specific circuits and conditions. Refer to the *Compensation* section for other design requirement.

## COMPENSATION

This section will present a general design procedure to help insure a stable and operational circuit. The designs in this datasheet are optimized for particular requirements. If different conversions are required, some of the components may need to be changed to ensure stability. Below is a set of general guidelines in designing a stable circuit for continuous conduction operation, in most all cases this will provide for stability during discontinuous operation as well. The power components and their effects will be determined first, then the compensation components will be chosen to produce stability.

## INDUCTOR AND DIODE SELECTION

Although the inductor sizes mentioned earlier are fine for most applications, a more exact value can be calculated. To ensure stability at duty cycles above 50%, the inductor must have some minimum value determined by the minimum input voltage and the maximum output voltage. This equation is:

$$L > \frac{V_{IN} R_{DSON}}{0.144 f_s} \left( \frac{D}{D'} - 1 \right) \text{ (in H)}$$

where

- $f_s$  is the switching frequency
- $D$  is the duty cycle
- $R_{DSON}$  is the ON resistance of the internal switch taken from the graph "NMOS  $R_{DSON}$  vs. Input Voltage" in the *Typical Performance Characteristics* section. (6)

This equation is only good for duty cycles greater than 50% ( $D > 0.5$ ), for duty cycles less than 50% the recommended values may be used. The corresponding inductor current ripple as shown in [Figure 22 \(a\)](#) is given by:

$$\Delta i_L = \frac{V_{IN} D}{2L f_s} \text{ (in Amps)} \quad (7)$$

The inductor ripple current is important for a few reasons. One reason is because the peak switch current will be the average inductor current (input current or  $I_{LOAD}/D'$ ) plus  $\Delta i_L$ . As a side note, discontinuous operation occurs when the inductor current falls to zero during a switching cycle, or  $\Delta i_L$  is greater than the average inductor current. Therefore, continuous conduction mode occurs when  $\Delta i_L$  is less than the average inductor current. Care must be taken to make sure that the switch will not reach its current limit during normal operation. The inductor must also be sized accordingly. It should have a saturation current rating higher than the peak inductor current expected. The output voltage ripple is also affected by the total ripple current.

The output diode for a boost regulator must be chosen correctly depending on the output voltage and the output current. The typical current waveform for the diode in continuous conduction mode is shown in [Figure 22 \(b\)](#). The diode must be rated for a reverse voltage equal to or greater than the output voltage used. The average current rating must be greater than the maximum load current expected, and the peak current rating must be greater than the peak inductor current. During short circuit testing, or if short circuit conditions are possible in the application, the diode current rating must exceed the switch current limit. Using Schottky diodes with lower forward voltage drop will decrease power dissipation and increase efficiency.

## DC GAIN AND OPEN-LOOP GAIN

Since the control stage of the converter forms a complete feedback loop with the power components, it forms a closed-loop system that must be stabilized to avoid positive feedback and instability. A value for open-loop DC gain will be required, from which you can calculate, or place, poles and zeros to determine the crossover frequency and the phase margin. A high phase margin (greater than 45°) is desired for the best stability and transient response. For the purpose of stabilizing the LM3224, choosing a crossover point well below where the right half plane zero is located will ensure sufficient phase margin.

To ensure a bandwidth of  $\frac{1}{2}$  or less of the frequency of the RHP zero, calculate the open-loop DC gain,  $A_{DC}$ . After this value is known, you can calculate the crossover visually by placing a  $-20\text{dB/decade}$  slope at each pole, and a  $+20\text{dB/decade}$  slope for each zero. The point at which the gain plot crosses unity gain, or  $0\text{dB}$ , is the crossover frequency. If the crossover frequency is less than  $\frac{1}{2}$  the RHP zero, the phase margin should be high enough for stability. The phase margin can also be improved by adding  $C_{C2}$  as discussed later in this section. The equation for  $A_{DC}$  is given below with additional equations required for the calculation:

$$A_{DC(\text{dB})} = 20\log_{10}\left\langle\left(\frac{R_{FB2}}{R_{FB1} + R_{FB2}}\right) \frac{g_m R_O D'}{R_{DSON}} \left\{ \left[ \frac{\omega C_{Leff}}{R_L} \right] / \left[ \frac{\omega C_{Leff}}{R_L} \right] \right\} \right\rangle \text{ (in dB)} \quad (8)$$

$$\omega C \cong \frac{2f_s}{nD'} \text{ (in rad/s)} \quad (9)$$

$$L_{eff} = \frac{L}{(D')^2} \quad (10)$$

$$n = 1 + \frac{2mc}{m1} \text{ (no unit)} \quad (11)$$

$$mc \cong 0.072f_s \text{ (in V/s)} \quad (12)$$

$$m1 \cong \frac{V_{IN} R_{DSON}}{L} \text{ (in V/s)}$$

where

- $R_L$  is the minimum load resistance
  - $V_{IN}$  is the minimum input voltage
  - $g_m$  is the error amplifier transconductance found in the *Electrical Characteristics* table
  - $R_{DSON}$  is the value chosen from the graph "NMOS  $R_{DSON}$  vs. Input Voltage" in the *Typical Performance Characteristics* section
- (13)

## INPUT AND OUTPUT CAPACITOR SELECTION

The switching action of a boost regulator causes a triangular voltage waveform at the input. A capacitor is required to reduce the input ripple and noise for proper operation of the regulator. The size used is dependant on the application and board layout. If the regulator will be loaded uniformly, with very little load changes, and at lower current outputs, the input capacitor size can often be reduced. The size can also be reduced if the input of the regulator is very close to the source output. The size will generally need to be larger for applications where the regulator is supplying nearly the maximum rated output or if large load steps are expected. A minimum value of 10 $\mu$ F should be used for the less stressful conditions while a 22 $\mu$ F to 47 $\mu$ F capacitor may be required for higher power and dynamic loads. Larger values and/or lower ESR may be needed if the application requires very low ripple on the input source voltage.

The choice of output capacitors is also somewhat arbitrary and depends on the design requirements for output voltage ripple. It is recommended that low ESR (Equivalent Series Resistance, denoted  $R_{ESR}$ ) capacitors be used such as ceramic, polymer electrolytic, or low ESR tantalum. Higher ESR capacitors may be used but will require more compensation which will be explained later on in the section. The ESR is also important because it determines the peak to peak output voltage ripple according to the approximate equation:

$$\Delta V_{OUT} \approx 2\Delta I_L R_{ESR} \text{ (in Volts)} \quad (14)$$

A minimum value of 10 $\mu$ F is recommended and may be increased to a larger value. After choosing the output capacitor you can determine a pole-zero pair introduced into the control loop by the following equations:

$$f_{P1} = \frac{1}{2\pi(R_{ESR} + R_L)C_{OUT}} \text{ (in Hz)} \quad (15)$$

$$f_{Z1} = \frac{1}{2\pi R_{ESR} C_{OUT}} \text{ (in Hz)}$$

where

- $R_L$  is the minimum load resistance corresponding to the maximum load current (16)

The zero created by the ESR of the output capacitor is generally very high frequency if the ESR is small. If low ESR capacitors are used it can be neglected. If higher ESR capacitors are used see the *High Output Capacitor ESR Compensation* section. Some suitable capacitor vendors include Vishay, Taiyo-Yuden, and TDK.

## RIGHT HALF PLANE ZERO

A current mode control boost regulator has an inherent right half plane zero (RHP zero). This zero has the effect of a zero in the gain plot, causing an imposed +20dB/decade on the rolloff, but has the effect of a pole in the phase, subtracting another 90° in the phase plot. This can cause undesirable effects if the control loop is influenced by this zero. To ensure the RHP zero does not cause instability issues, the control loop should be designed to have a bandwidth of less than ½ the frequency of the RHP zero. This zero occurs at a frequency of:

$$\text{RHPzero} = \frac{V_{OUT}(D')^2}{2\pi I_{LOAD}L} \text{ (in Hz)}$$

where

- $I_{LOAD}$  is the maximum load current. (17)

## SELECTING THE COMPENSATION COMPONENTS

The first step in selecting the compensation components  $R_C$  and  $C_C$  is to set a dominant low frequency pole in the control loop. Simply choose values for  $R_C$  and  $C_C$  within the ranges given in the *Introduction to Compensation* section to set this pole in the area of 10Hz to 500Hz. The frequency of the pole created is determined by the equation:

$$f_{PC} = \frac{1}{2\pi(R_C + R_O)C_C} \text{ (in Hz)}$$

where

- $R_O$  is the output impedance of the error amplifier, approximately 900k $\Omega$  (18)

Since  $R_C$  is generally much less than  $R_O$ , it does not have much effect on the above equation and can be neglected until a value is chosen to set the zero  $f_{ZC}$ .  $f_{ZC}$  is created to cancel out the pole created by the output capacitor,  $f_{P1}$ . The output capacitor pole will shift with different load currents as shown by the equation, so setting the zero is not exact. Determine the range of  $f_{P1}$  over the expected loads and then set the zero  $f_{ZC}$  to a point approximately in the middle. The frequency of this zero is determined by:

$$f_{ZC} = \frac{1}{2\pi C_C R_C} \text{ (in Hz)} \quad (19)$$

Now  $R_C$  can be chosen with the selected value for  $C_C$ . Check to make sure that the pole  $f_{PC}$  is still in the 10Hz to 500Hz range, change each value slightly if needed to ensure both component values are in the recommended range.

## HIGH OUTPUT CAPACITOR ESR COMPENSATION

When using an output capacitor with a high ESR value, or just to improve the overall phase margin of the control loop, another pole may be introduced to cancel the zero created by the ESR. This is accomplished by adding another capacitor,  $C_{C2}$ , directly from the compensation pin  $V_C$  to ground, in parallel with the series combination of  $R_C$  and  $C_C$ . The pole should be placed at the same frequency as  $f_{Z1}$ , the ESR zero. The equation for this pole follows:

$$f_{PC2} = \frac{1}{2\pi C_{C2}(R_C // R_O)} \text{ (in Hz)} \quad (20)$$

To ensure this equation is valid, and that  $C_{C2}$  can be used without negatively impacting the effects of  $R_C$  and  $C_C$ ,  $f_{PC2}$  must be greater than  $10f_{ZC}$ .

## CHECKING THE DESIGN

With all the poles and zeros calculated the crossover frequency can be checked as described in the section *DC Gain and Open-loop Gain*. The compensation values can be changed a little more to optimize performance if desired. This is best done in the lab on a bench, checking the load step response with different values until the ringing and overshoot on the output voltage at the edge of the load steps is minimal. This should produce a stable, high performance circuit. For improved transient response, higher values of  $R_C$  should be chosen. This will improve the overall bandwidth which makes the regulator respond more quickly to transients. If more detail is required, or the most optimum performance is desired, refer to a more in depth discussion of compensating current mode DC/DC switching regulators.

## POWER DISSIPATION

The output power of the LM3224 is limited by its maximum power dissipation. The maximum power dissipation is determined by the formula

$$P_D = (T_{jmax} - T_A) / \theta_{JA}$$

where

- $T_{jmax}$  is the maximum specified junction temperature (125°C)
  - $T_A$  is the ambient temperature
  - $\theta_{JA}$  is the thermal resistance of the package
- (21)

## LAYOUT CONSIDERATIONS

The input bypass capacitor  $C_{IN}$ , as shown in the typical operating circuit, must be placed close to the IC. This will reduce copper trace resistance which effects input voltage ripple of the IC. For additional input voltage filtering, a 100nF bypass capacitor can be placed in parallel with  $C_{IN}$ , close to the  $V_{IN}$  pin, to shunt any high frequency noise to ground. The output capacitor,  $C_{OUT}$ , should also be placed close to the IC. Any copper trace connections for the  $C_{OUT}$  capacitor can increase the series resistance, which directly effects output voltage ripple. The feedback network, resistors  $R_{FB1}$  and  $R_{FB2}$ , should be kept close to the FB pin, and away from the inductor, to minimize copper trace connections that can inject noise into the system. Trace connections made to the inductor and schottky diode should be minimized to reduce power dissipation and increase overall efficiency. For more detail on switching power supply layout considerations see Application Note *Layout Guidelines for Switching Power Supplies* (SNVA021).

## APPLICATION INFORMATION

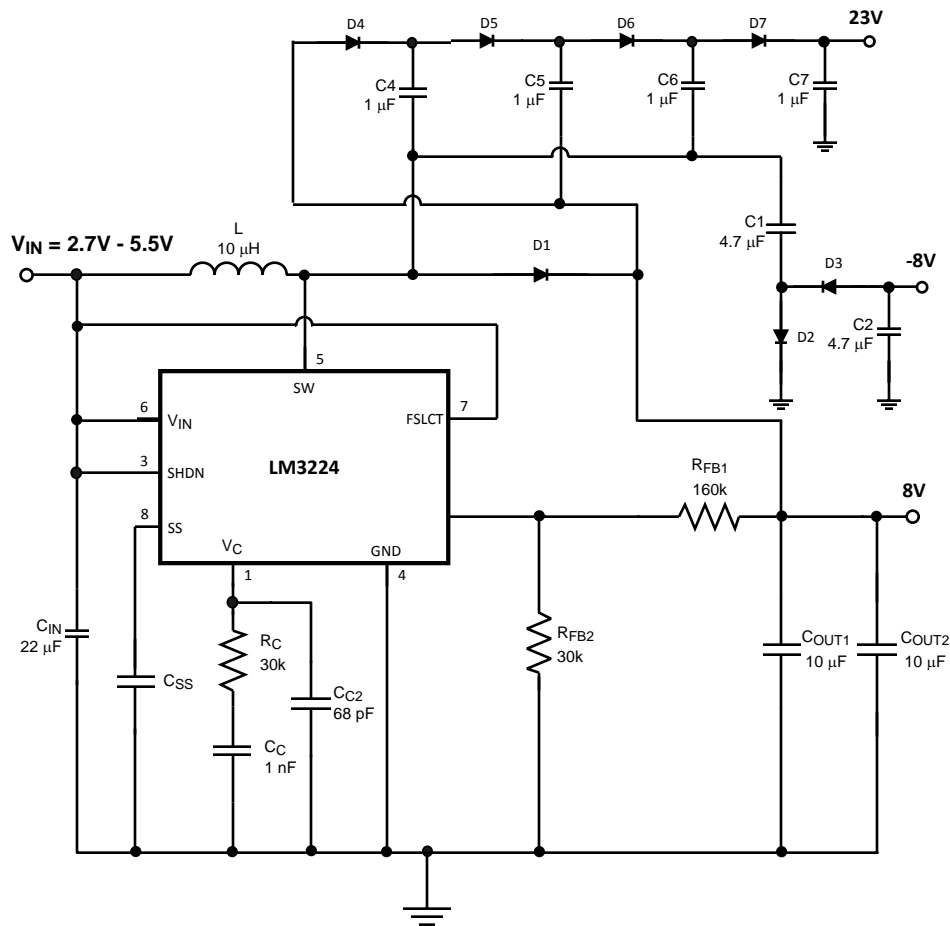

Figure 23. Triple Output TFT Bias (615 kHz operation)

### TRIPLE OUTPUT TFT BIAS

The circuit in [Figure 23](#) shows how the LM3224 can be configured to provide outputs of 8V, -8V, and 23V, convenient for biasing TFT displays. The 8V output is regulated, while the -8V and 23V outputs are unregulated.

The 8V output is generated by a typical boost topology. The basic operation of the boost converter is described in the OPERATION section. The output voltage is set with  $R_{FB1}$  and  $R_{FB2}$  by:

$$R_{FB1} = R_{FB2} \frac{V_{OUT} - 1.26}{1.26} \Omega \quad (22)$$

The compensation network of  $R_C$  and  $C_C$  are chosen to optimally stabilize the converter. The inductor also affects the stability. When operating at 615 kHz, a 10µH inductor is recommended to insure the converter is stable at duty cycles greater than 50%. Refer to the COMPENSATION section for more information.

The -8V output is derived from a diode inverter. During the second cycle, when the transistor is open, D2 conducts and C1 charges to 8V minus a diode drop ( $\approx 0.4V$  if using a Schottky). When the transistor opens in the first cycle, D3 conducts and C1's polarity is reversed with respect to the output at C2, producing -8V.



The 23V output is realized with a series of capacitor charge pumps. It consists of four stages: the first stage includes C4, D4, and the LM3224 switch; the second stage uses C5, D5, and D1; the third stage includes C6, D6, and the LM3224 switch; the final stage is C7 and D7. In the first stage, C4 charges to 8V when the LM3224 switch is closed, which causes D5 to conduct when the switch is open. In the second stage, the voltage across C5 is  $V_{C4} + V_{D1} - V_{D5} = V_{C4} \approx 8V$  when the switch is open. However, because C5 is referenced to the 8V output, the voltage at C5 is 16V when referenced to ground. In the third stage, the 16V at C5 appears across C6 when the switch is closed. When the switch opens, C6 is referenced to the 8V output minus a diode drop, which raises the voltage at C6 with respect to ground to about 24V. Hence, in the fourth stage, C7 is charged to 24V when the switch is open. From the first stage to the last, there are three diode drops that make the output voltage closer to  $24 - 3 \times V_{DIODE}$  (about 22.8V if a 0.4V forward drop is assumed).

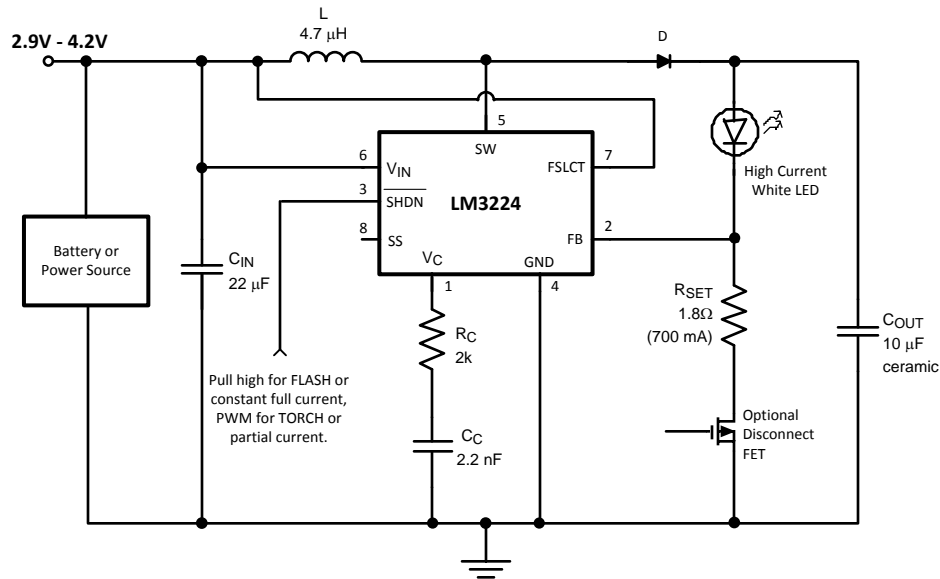

Figure 24. PWM White LED Flash/Torch Driver

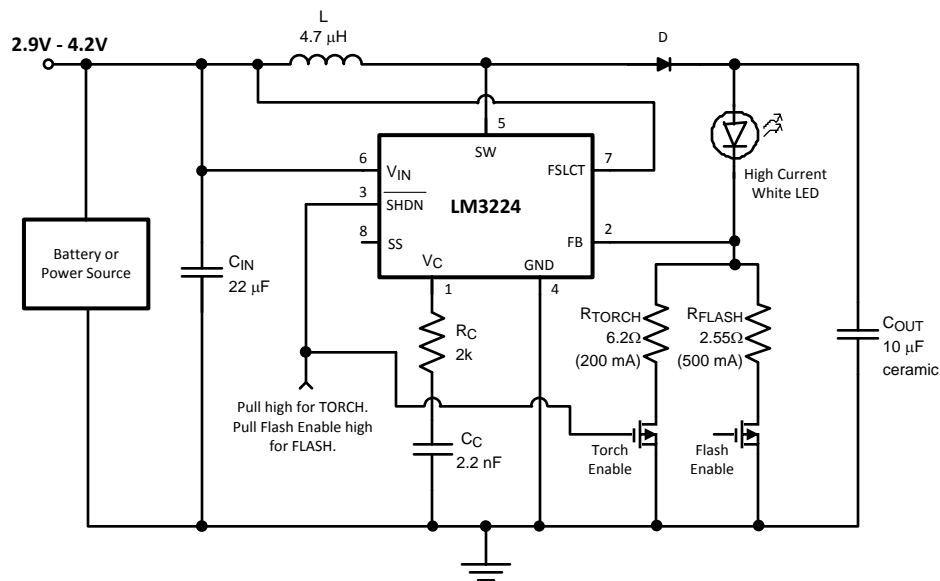

Figure 25. Continuously Operating White LED Flash/Torch Driver

The LM3224 can be configured to drive high current white LEDs for the flash and torch functions of a digital camera, camera phone, or any other similar light source. The flash/torch can be set up with the circuit in [Figure 24](#) by using the resistor  $R_{SET}$  to determine the amount of current that will flow through the LED using the equation:

$$I_{LED} = V_{FB}/R_{SET} \quad (23)$$

If the flash and torch modes will both be used the resistor  $R_{SET}$  can be chosen for the higher current flash value. To flash the circuit pull the  $\overline{SHDN}$  high for the time duration needed for the flash. To enable a lower current torch mode a PWM signal can be applied to the  $\overline{SHDN}$  pin. The torch current would then be approximately the percent ON time of the PWM signal multiplied by the flash (or maximum) current. The optional disconnect FET can be used to eliminate leakage current through the LEDs when the part is off and also to disconnect the LED when the input voltage exceeds the forward voltage drop of the LED. The maximum output current the LM3224 can supply in this configuration is shown in [Table 1](#).

[Figure 25](#) is another method of driving a high current white LED. This circuit has a higher component count but allows the switcher to remain on continuously for torch mode reducing stress on the supply. The two FETs also double for a disconnect function as described above. In this circuit the device and the torch enable FET are turned on setting a lower current through the LED. When flash is needed the flash enable FET is turned on to increase the current for the amount of time desired. The minimum ensured maximum output current for this circuit is the same as for [Figure 24](#).

**Table 1. Maximum LED Drive current**  
( $F_{SW}=1.25\text{MHz}$ ,  $L=4.7\mu\text{H}$ , LED  $V_{FMAX}=4\text{V}$  ( $V_{OUT}=5.26\text{V}$ ))

$V_{IN}$	LED Drive Current (mA)
4.2	1077
4.1	1047
4.0	1017
3.9	987
3.8	958
3.7	929
3.6	900
3.5	871
3.4	842
3.3	814
3.2	785
3.1	757
3.0	729
2.9	701
2.8	673
2.7	646

**Table 2. Some Recommended Inductors (Others May Be Used)**

Manufacturer	Inductor	Contact Information
Coilcraft	DO3316 and DT3316 series	<a href="http://www.coilcraft.com">www.coilcraft.com</a> 800-3222645
TDK	SLF10145 series	<a href="http://www.component.tdk.com">www.component.tdk.com</a> 847-803-6100
Pulse	P0751 and P0762 series	<a href="http://www.pulseeng.com">www.pulseeng.com</a>
Sumida	CDRH8D28 and CDRH8D43 series	<a href="http://www.sumida.com">www.sumida.com</a>

**Table 3. Some Recommended Input And Output Capacitors (Others May Be Used)**

Manufacturer	Capacitor	Contact Information
Vishay Sprague	293D, 592D, and 595D series tantalum	<a href="http://www.vishay.com">www.vishay.com</a> 407-324-4140
Taiyo Yuden	High capacitance MLCC ceramic	<a href="http://www.t-yuden.com">www.t-yuden.com</a> 408-573-4150
Cornell Dubilier	ESRD series Polymer Aluminum Electrolytic SPV and AFK series V-chip series	<a href="http://www.cde.com">www.cde.com</a>
MuRata	High capacitance MLCC ceramic	<a href="http://www.murata.com">www.murata.com</a>

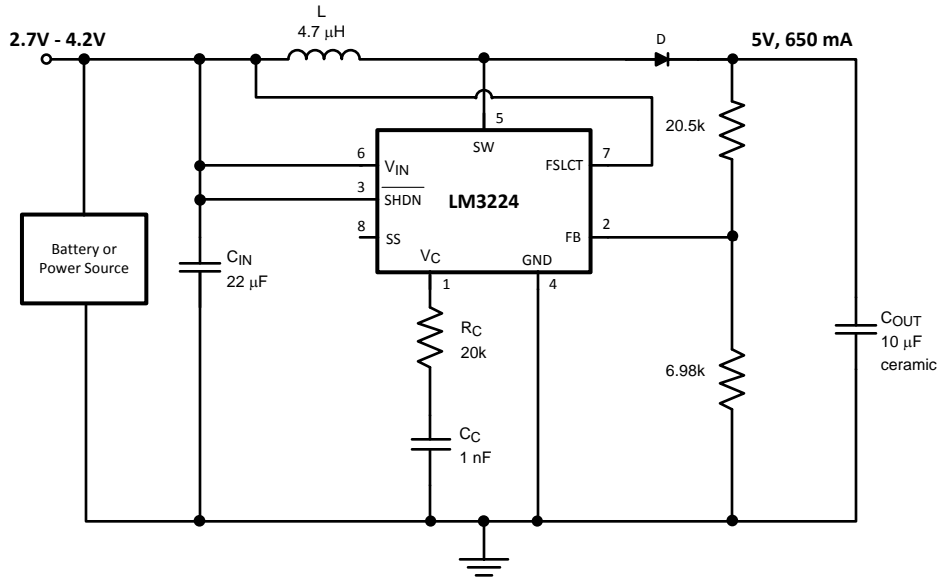

**Figure 26. 1.25MHz, 5V Output**

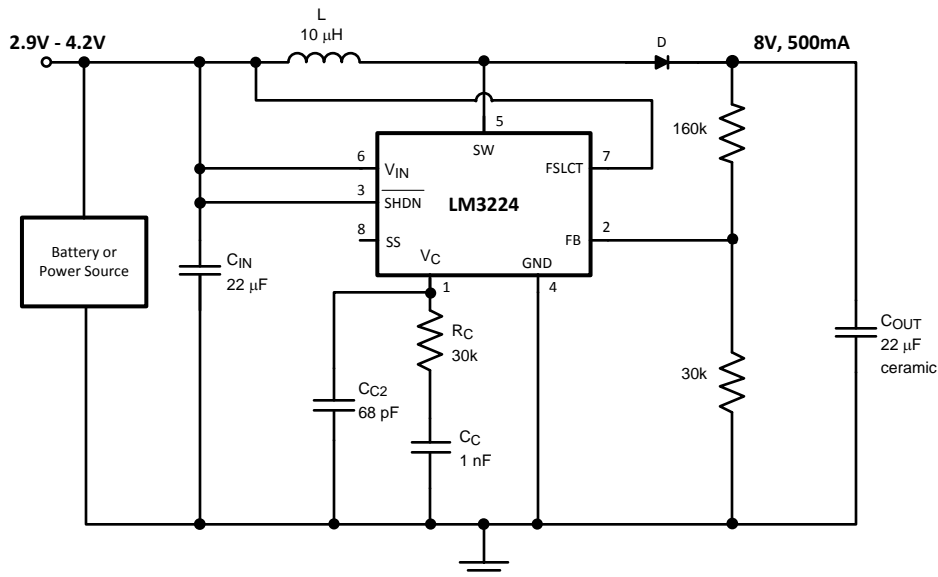

**Figure 27. 1.25MHz, 8V Output**

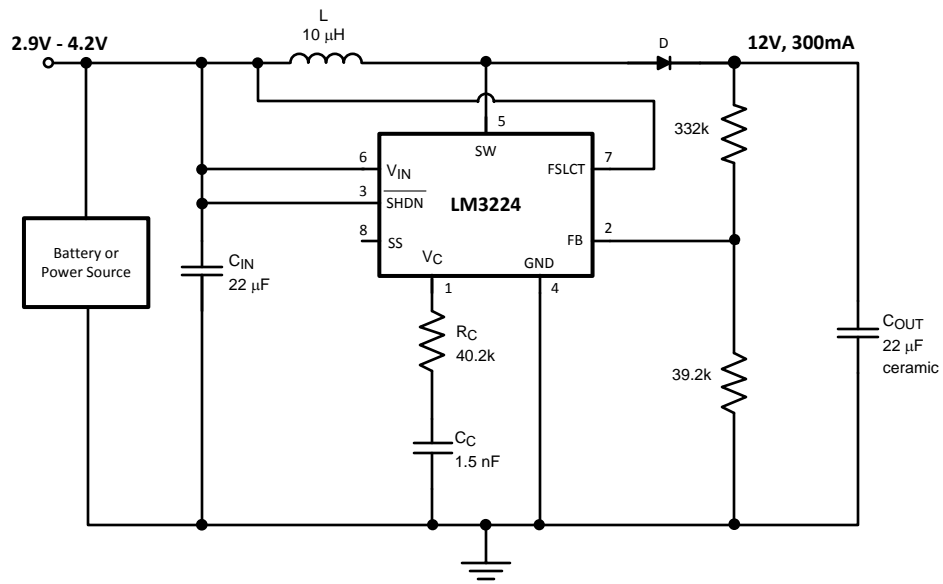

Figure 28. 1.25MHz, 12V Output

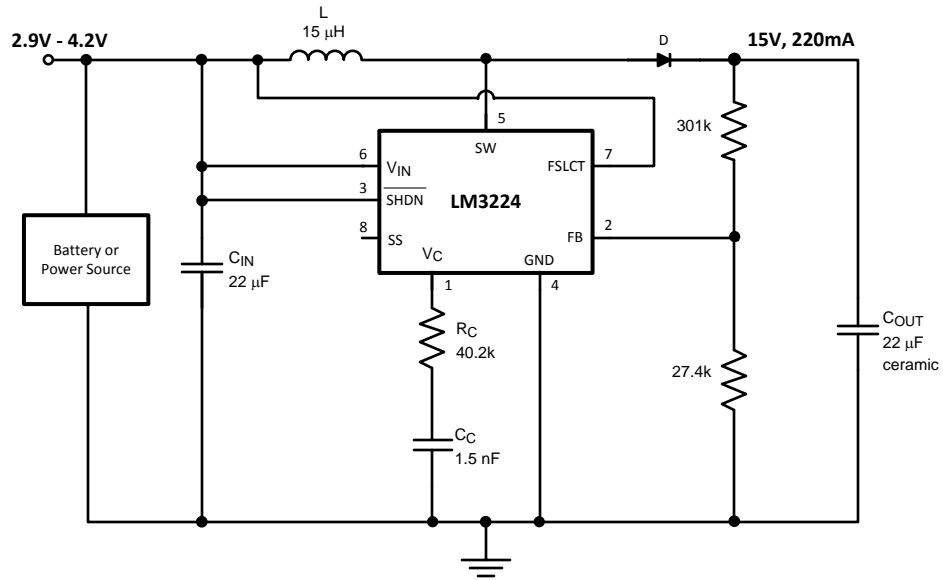

Figure 29. 1.25MHz, 15V Output

---

**REVISION HISTORY**

<b>Changes from Revision B (March 2013) to Revision C</b>	<b>Page</b>
<hr/> <ul style="list-style-type: none"><li>• Changed layout of National Data Sheet to TI format .....</li></ul>	<hr/> <a href="#">20</a>

**PACKAGING INFORMATION**

Orderable Device	Status (1)	Package Type	Package Drawing	Pins	Package Qty	Eco Plan (2)	Lead finish/ Ball material (6)	MSL Peak Temp (3)	Op Temp (°C)	Device Marking (4/5)	Samples
LM3224MM-ADJ/NOPB	ACTIVE	VSSOP	DGK	8	1000	RoHS & Green	SN	Level-1-260C-UNLIM	-40 to 125	SEKB	<b>Samples</b>
LM3224MMX-ADJ/NOPB	ACTIVE	VSSOP	DGK	8	3500	RoHS & Green	SN	Level-1-260C-UNLIM		SEKB	<b>Samples</b>

(1) The marketing status values are defined as follows:

**ACTIVE:** Product device recommended for new designs.

**LIFEBUY:** TI has announced that the device will be discontinued, and a lifetime-buy period is in effect.

**NRND:** Not recommended for new designs. Device is in production to support existing customers, but TI does not recommend using this part in a new design.

**PREVIEW:** Device has been announced but is not in production. Samples may or may not be available.

**OBSOLETE:** TI has discontinued the production of the device.

(2) **RoHS:** TI defines "RoHS" to mean semiconductor products that are compliant with the current EU RoHS requirements for all 10 RoHS substances, including the requirement that RoHS substance do not exceed 0.1% by weight in homogeneous materials. Where designed to be soldered at high temperatures, "RoHS" products are suitable for use in specified lead-free processes. TI may reference these types of products as "Pb-Free".

**RoHS Exempt:** TI defines "RoHS Exempt" to mean products that contain lead but are compliant with EU RoHS pursuant to a specific EU RoHS exemption.

**Green:** TI defines "Green" to mean the content of Chlorine (Cl) and Bromine (Br) based flame retardants meet JS709B low halogen requirements of <=1000ppm threshold. Antimony trioxide based flame retardants must also meet the <=1000ppm threshold requirement.

(3) MSL, Peak Temp. - The Moisture Sensitivity Level rating according to the JEDEC industry standard classifications, and peak solder temperature.

(4) There may be additional marking, which relates to the logo, the lot trace code information, or the environmental category on the device.

(5) Multiple Device Markings will be inside parentheses. Only one Device Marking contained in parentheses and separated by a "~" will appear on a device. If a line is indented then it is a continuation of the previous line and the two combined represent the entire Device Marking for that device.

(6) Lead finish/Ball material - Orderable Devices may have multiple material finish options. Finish options are separated by a vertical ruled line. Lead finish/Ball material values may wrap to two lines if the finish value exceeds the maximum column width.

**Important Information and Disclaimer:**The information provided on this page represents TI's knowledge and belief as of the date that it is provided. TI bases its knowledge and belief on information provided by third parties, and makes no representation or warranty as to the accuracy of such information. Efforts are underway to better integrate information from third parties. TI has taken and continues to take reasonable steps to provide representative and accurate information but may not have conducted destructive testing or chemical analysis on incoming materials and chemicals. TI and TI suppliers consider certain information to be proprietary, and thus CAS numbers and other limited information may not be available for release.

In no event shall TI's liability arising out of such information exceed the total purchase price of the TI part(s) at issue in this document sold by TI to Customer on an annual basis.



## TAPE AND REEL INFORMATION



### QUADRANT ASSIGNMENTS FOR PIN 1 ORIENTATION IN TAPE



\*All dimensions are nominal

Device	Package Type	Package Drawing	Pins	SPQ	Reel Diameter (mm)	Reel Width W1 (mm)	A0 (mm)	B0 (mm)	K0 (mm)	P1 (mm)	W (mm)	Pin1 Quadrant
LM3224MM-ADJ/NOPB	VSSOP	DGK	8	1000	178.0	12.4	5.3	3.4	1.4	8.0	12.0	Q1
LM3224MMX-ADJ/NOPB	VSSOP	DGK	8	3500	330.0	12.4	5.3	3.4	1.4	8.0	12.0	Q1



**TAPE AND REEL BOX DIMENSIONS**

\*All dimensions are nominal

Device	Package Type	Package Drawing	Pins	SPQ	Length (mm)	Width (mm)	Height (mm)
LM3224MM-ADJ/NOPB	VSSOP	DGK	8	1000	210.0	185.0	35.0
LM3224MMX-ADJ/NOPB	VSSOP	DGK	8	3500	367.0	367.0	35.0

DGK (S-PDSO-G8)

PLASTIC SMALL-OUTLINE PACKAGE



- NOTES:
- A. All linear dimensions are in millimeters.
  - B. This drawing is subject to change without notice.
  - C. Body length does not include mold flash, protrusions, or gate burrs. Mold flash, protrusions, or gate burrs shall not exceed 0.15 per end.
  - D. Body width does not include interlead flash. Interlead flash shall not exceed 0.50 per side.
  - E. Falls within JEDEC MO-187 variation AA, except interlead flash.



- NOTES:
- A. All linear dimensions are in millimeters.
  - B. This drawing is subject to change without notice.
  - C. Publication IPC-7351 is recommended for alternate designs.
  - D. Laser cutting apertures with trapezoidal walls and also rounding corners will offer better paste release. Customers should contact their board assembly site for stencil design recommendations. Refer to IPC-7525 for other stencil recommendations.
  - E. Customers should contact their board fabrication site for solder mask tolerances between and around signal pads.

## IMPORTANT NOTICE AND DISCLAIMER

TI PROVIDES TECHNICAL AND RELIABILITY DATA (INCLUDING DATASHEETS), DESIGN RESOURCES (INCLUDING REFERENCE DESIGNS), APPLICATION OR OTHER DESIGN ADVICE, WEB TOOLS, SAFETY INFORMATION, AND OTHER RESOURCES "AS IS" AND WITH ALL FAULTS, AND DISCLAIMS ALL WARRANTIES, EXPRESS AND IMPLIED, INCLUDING WITHOUT LIMITATION ANY IMPLIED WARRANTIES OF MERCHANTABILITY, FITNESS FOR A PARTICULAR PURPOSE OR NON-INFRINGEMENT OF THIRD PARTY INTELLECTUAL PROPERTY RIGHTS.

These resources are intended for skilled developers designing with TI products. You are solely responsible for (1) selecting the appropriate TI products for your application, (2) designing, validating and testing your application, and (3) ensuring your application meets applicable standards, and any other safety, security, or other requirements. These resources are subject to change without notice. TI grants you permission to use these resources only for development of an application that uses the TI products described in the resource. Other reproduction and display of these resources is prohibited. No license is granted to any other TI intellectual property right or to any third party intellectual property right. TI disclaims responsibility for, and you will fully indemnify TI and its representatives against, any claims, damages, costs, losses, and liabilities arising out of your use of these resources.

TI's products are provided subject to TI's Terms of Sale ([www.ti.com/legal/termsofsale.html](http://www.ti.com/legal/termsofsale.html)) or other applicable terms available either on [ti.com](http://ti.com) or provided in conjunction with such TI products. TI's provision of these resources does not expand or otherwise alter TI's applicable warranties or warranty disclaimers for TI products.

Mailing Address: Texas Instruments, Post Office Box 655303, Dallas, Texas 75265  
Copyright © 2020, Texas Instruments Incorporated